



# VONNE Directory 2016



**VONNE**  
voluntary organisations' network north east

# Contents

North East VCSE Networks	3
Local Infrastructure Organisations and Volunteer Centres	6
Key North East funders	9
Local authorities and their VCSE leads	13
Key public sector contacts	15
North East MPs and MEPs	19
Health and Wellbeing Landscape	22
NHS England	22
Public Health England	23
Directors of Public Health	24
Health and Wellbeing Boards	25
Clinical Commissioning Groups	28
Local Authority Adult Social Care Services	30
North East Care Act Leads	31
Healthwatch	32
North East Joint Strategic Needs Assessments	33
Care Quality Commission	35
Clinical Networks and Senate	36
Sustainability and Transformation Plans	39
North East Health Scrutiny Bodies	40
Criminal Justice System in the North East	41

## Directory

Welcome to our annual directory of key contacts for the VCSE in the North East. From major funders, public sector agencies, to MPs, health and criminal justice contacts, it's the must have publication to have on your desk for the coming year.

We hope you find it useful and welcome your feedback on it.



# North East VCSE Networks

This is a list of VCSE focused networks and forums that operate across the North East. Some are multi-agency networks, but have been included as they are significant for the VCSE. This list is by no means exhaustive, and if you know of a regional VCSE network that should be included please let us know. We'll be keeping an up-to-date list of these networks on our website at [www.vonne.org.uk/directories](http://www.vonne.org.uk/directories).

Network	Remit	Contact  
<b>Criminal Justice</b>		
North East Criminal Justice Policy Forum	Forum allowing a two way stream of information sharing with regards to national policy change and regional responses.	abi.lunn@clinks.org
North East Housing for Offenders Group	Subgroup of the North East Regional Homelessness Forum (NERHF) tackling specific challenges around housing for those that have experience with the Criminal Justice System.	abi.lunn@clinks.org
Northern Local Offender Partnership	To gather information about what is happening across the region in prisons and in the community to support offenders.	jenniferesther.carvell@hmpr.gsi.gov.uk
Prison and Offender Research in Social Care and Health (PORSCH) Network	PORSCH is a network of researchers and service practitioners based in the North East of England. It is dedicated to enhancing the contribution of research and development to the improvement of the health of offenders, the well-being of the communities in which they live and the reduction of offending behaviours.	profandrewgray@btinternet.com
<b>Homeless/Housing</b>		
Be The Change Network	Network of front line practitioners working to improve the skills of homelessness profession as well as services for the homeless.	bethechange@homelesslink.org.uk
North East Housing Community Led Development Network	To promote proactive, peer-to-peer learning to help create fertile ground for community-led housing initiatives and to help to deliver growth in the sector.	Victoria.Keen@hca.gsi.gov.uk Lucy.Gaffney@hca.gsi.gov.uk
North East Homelessness Think Tank	Comprises of academics, researchers, policy officers and aims to inform and influence policies affecting homeless client groups through research, campaigning and other collaborative activities.	youthhomelessnortheast.org.uk/nehtt/ Sheila.spencer@phonecoop.coop
North East Regional Homelessness Group	Forum with multi-sector involvement looking at key issues from a regional perspective to improve services for homeless. Encouraging communications between homelessness sector and local authority to share learning /best practice.	www.homeless.org.uk
Northern Neurological Alliance	Helps people who live or care for someone with a neurological condition. Working with partners to deliver information, events, opportunity and choice.	kbowman@na-na.org.uk
Youth Homeless North East	Provides a regional focus to address youth homelessness through policy and strategy.	www.youthhomelessnortheast.org.uk info@youthhomelessnortheast.org.uk

# North East VCSE Networks

Network	Remit	Contact  
<b>Health and Wellbeing</b>		
HAREF (Health and Race Equality Forum)	Health and Race Equality Forum is a network of organisations, community groups and individuals who work in health and community settings focused on reducing health inequalities experienced by people in Black and Minority Ethnic (BME) communities.	<a href="http://www.haref.org.uk">www.haref.org.uk</a>
Mental Health North East	A consortium organisation, aims to support VCOs whose work involves mental health. Promotes joint working and partnership across the not for profit mental health sector in the North East of England.	<a href="mailto:admin@mhne.org.uk">admin@mhne.org.uk</a>
North East Autism Consortium	An informal collaboration of individuals and groups working to implement the national autism strategy in local areas. NEAC works strategically to influence commissioning decisions in health and social care.	Pam Lawrence, Project Manager <a href="mailto:pamjlawrence1@gmail.com">pamjlawrence1@gmail.com</a> <a href="http://www.northeastautismconsortium.co.uk">www.northeastautismconsortium.co.uk</a>
North East Dementia Alliance	Partnership of key organisations and individuals concerned with the effective development and implementation of the National Dementia Strategy in the North East.	<a href="mailto:neda@newcastle.ac.uk">neda@newcastle.ac.uk</a> <a href="http://www.ncl.ac.uk/ageing/innovation/engagement/neda.htm">www.ncl.ac.uk/ageing/innovation/engagement/neda.htm</a>
North East Special Needs Network	Works in partnership with groups to influence service provision and the development of services.	<a href="http://www.nsn.org.uk">www.nsn.org.uk</a>
Reach Out North East	MHNE's Young People and Mental Health Project.	<a href="mailto:mhneworker@mhne.co.uk">mhneworker@mhne.co.uk</a>
<b>Infrastructure</b>		
Co-operatives North East	The aim of CNE is to see growth in North East England's co-operative sector across Northumberland, Tyne and Wear and Durham	<a href="http://www.cooperatives-ne.coop">www.cooperatives-ne.coop</a>
North East Local Infrastructure Organisations Network	To share information and discussion common issues, priorities and opportunities across local infrastructure organisations. Meets regionally twice a year and more frequently at combined local authority level.	Carol Botten, Deputy CEO of VONNE <a href="mailto:carol.botten@vonne.org.uk">carol.botten@vonne.org.uk</a>
<b>Employability and economy</b>		
NECA area VCSE Skills & Employability Focus Group	To bring together VCSE organisations working in skills employability to share knowledge, experience, opportunities and to work together more effectively.	Co-ordinated by VONNE. <a href="mailto:vonne@vonne.org.uk">vonne@vonne.org.uk</a>
Tees Valley VCSE Economic Growth & Inclusion Working Group	The group exists to act as a coherent voice for the VCSE sector in Tees Valley and support the VCSE sector to be an equal & integral partner within the Tees Valley economic growth and social inclusion agenda.	Co-ordinated by VONNE. <a href="mailto:vonne@vonne.org.uk">vonne@vonne.org.uk</a>

Network	Remit	Contact  
<b>Other networks</b>		
Connecting for Change	A cross sector equality network ran by Equality North East.	<a href="http://www.equality-ne.co.uk">www.equality-ne.co.uk</a>
Emerging Leaders Network North	ELNN is space for aspiring NE voluntary sector leaders to learn from and about each other in a supportive environment.	<a href="http://emergingleadersnorth.wordpress.com">emergingleadersnorth.wordpress.com</a>
Multiple Needs and Exclusion Forum	Multi-sector partnership to share good practice and learning across the North East.	<a href="mailto:abi.lunn@clinks.org">abi.lunn@clinks.org</a>
North East Child Poverty Network	The group meets quarterly across the North East region to discuss key policy and impact on poverty, and to share approaches.	<a href="mailto:satty.rai@northern-consortium.org.uk">satty.rai@northern-consortium.org.uk</a> <a href="http://www.northern-consortium.org.uk/event/north-east-child-poverty-network-2/">www.northern-consortium.org.uk/event/north-east-child-poverty-network-2/</a>
North East Combined Transport Activists Roundtable	This forum is for organisations with an interest in sustainable transport in all its forms to develop a co-ordinated view on contemporary transport issues.	<a href="https://www.facebook.com/groups/nectar.transport">www.facebook.com/groups/nectar.transport</a>
North East Culture Partnership	Multi-sector partnership which aims to build on foundations laid through the North East's cultural regeneration to harness the power of culture to promote health and well-being and to forge a dynamic and successful economy.	<a href="http://case4culture.org.uk">case4culture.org.uk</a>
North East Funders Network	To enable funders to be better networked, better informed and work together more effectively to improve and maximise their support to North East communities	VONNE - Chair/ coordinator <a href="http://www.vonne.org.uk/fine">www.vonne.org.uk/fine</a>
North East Social Leaders Network	Multi-sector network for leaders interested in social change. Hosts events, working groups and coaching.	<a href="http://www.ncl.ac.uk/kite/socialrenewal/netogether.htm">www.ncl.ac.uk/kite/socialrenewal /netogether.htm</a>
North East Women's Network	Encourages and supports collaboration between women's VCOs and building partnerships and alliances with other sectors.	Sue Robson <a href="mailto:info@newwomens.net">info@newwomens.net</a> <a href="http://www.newwomens.net">www.newwomens.net</a>
Regional Refugee Forum North East	Independent membership organisation of the North East region's Refugee-led Community Organisations, enabling their collective voice to be heard by decision makers to influence policy and services.	<a href="http://www.refugeevoices.org.uk">www.refugeevoices.org.uk</a> <a href="mailto:georgina.fletcher@refugeevoices.org.uk">georgina.fletcher@refugeevoices.org.uk</a>
The North East Migration Partnership VCS forum	Provides strategic leadership, co-ordination and advisory function for migration in the North East Region.	<a href="mailto:nemp@middlesbrough.gov.uk">nemp@middlesbrough.gov.uk</a>
Youth Focus North East	As part of their support to young people's voice and participation Youth Focus: North East facilitate the North East 'You're Welcome' Health & Participation Leads Network. This network involves members from Statutory and VCS organisations within health and the youth/ community sector.	<a href="http://www.youthfocusne.org.uk">www.youthfocusne.org.uk</a>

# Local Infrastructure Organisations

## Tyne and Wear

### Newcastle Council for Voluntary Service

Chief Executive: Sally Young

Higham House, Higham Place,  
Newcastle upon Tyne, Tyne & Wear, NE1 8AF

 0191 232 7445

 [ncvs@cvsnewcastle.org.uk](mailto:ncvs@cvsnewcastle.org.uk)

 [www.cvsnewcastle.org.uk](http://www.cvsnewcastle.org.uk)

### North Tyneside Voluntary Organisations Development Agency

Chief Executive: Lisa Goodwin

Queen Alexandra Campus, Hawkeys Lane  
North Shields, Tyne & Wear, NE29 9BZ

 0191 643 2626

 [admin@voda.org.uk](mailto:admin@voda.org.uk)

 [www.voda.org.uk](http://www.voda.org.uk)

### South Tyneside Council for Voluntary Service

Business Manager: Debbie Carr

John Hunt House, 27 Beach Road, South Shields,  
Tyne & Wear, NE33 2QA

 0191 456 9551

 [enquiries@stcvs.org.uk](mailto:enquiries@stcvs.org.uk)

 [www.stcvs.org.uk](http://www.stcvs.org.uk)

### Voluntary and Community Action Sunderland

Manager: Gillian McDonough

8 Frederick Street, Sunderland, Tyne & Wear,  
SR1 1NA

 0191 565 1566

 [info@vcas.org.uk](mailto:info@vcas.org.uk)

 [www.VCASunderland.org.uk](http://www.VCASunderland.org.uk)

## Northumberland

### Community Action Northumberland

Chief Executive: Andy Dean

UNIUN Enterprise Centre, Front Street, Pegswood,  
Morpeth, Northumberland, NE61 6RG

 01670 517 178

 [info@ca-north.org.uk](mailto:info@ca-north.org.uk)

 [www.ca-north.org.uk](http://www.ca-north.org.uk)

### Community and Voluntary Action Blyth Valley

Chief Executive Officer: Thom Bradley

22 Beaconsfield Street, Blyth, Northumberland  
NE24 2DP

 01670 353 623

 [info@cvabv.org.uk](mailto:info@cvabv.org.uk)

 [www.cvabv.org.uk](http://www.cvabv.org.uk)

### Northumberland Community Voluntary Action

Chief Executive Officer: Anne Lyall

107 & 109 Station Road, Ashington,  
Northumberland, NE63 8RS

 01670 858 688

 [enquire@northumberlandcva.org.uk](mailto:enquire@northumberlandcva.org.uk)

 [www.northumberlandcva.org.uk](http://www.northumberlandcva.org.uk)

## Tees Valley

### Catalyst Stockton on Tees Ltd

Chief Executive Officer: Steve Rose

Catalyst House, 27 Yarm Road, Stockton-on-Tees,  
TS18 3NJ

 01642 733 906

 [enquiries@catalyststockton.org](mailto:enquiries@catalyststockton.org)

 [www.catalyststockton.org](http://www.catalyststockton.org)

### Hartlepool Voluntary Development Agency

Manager: Keith Bayley

Rockhaven, 36 Victoria Road, Hartlepool,  
TS26 8DD

 01429 262 641

 [info@hvda.co.uk](mailto:info@hvda.co.uk)

 [www.hvda.org.uk](http://www.hvda.org.uk)

## Tees Valley (continued)

### Middlesbrough Voluntary Development Agency

Chief Executive Officer: Mark Davis

St Mary's Centre, 82-90 Corporation Road,  
Middlesbrough, TS1 2RW

☎ 01642 249 300

✉ [general@mvdauk.org.uk](mailto:general@mvdauk.org.uk)

💻 [www.mvda.info](http://www.mvda.info)

### Redcar & Cleveland Voluntary Development Agency

Chief Executive Officer: Mike Milen

Westfield Farm, The Green, Dormanstown,  
TS10 5NA

☎ 01642 440 571

✉ [enquiries@rcvda.org.uk](mailto:enquiries@rcvda.org.uk)

💻 [www.rcvda.org.uk](http://www.rcvda.org.uk)

### Stockton Residents & Community Groups Association

Chief Executive Officer: Julie Derbyshire

27 Yarm Road, Stockton-on-Tees, TS18 3NJ

☎ 01642 733 912

✉ [info@srcga.com](mailto:info@srcga.com)

💻 [www.srcga.co.uk](http://www.srcga.co.uk)

### Tees Valley Rural Community Council

Chief Officer: Rita Lawson

Unit 2A, Cadcam Centre, High Force Road,  
Riverside Park, Middlesbrough, TS2 1RH

☎ 01642 213 852

✉ [admin@teesvalleyrcc.org.uk](mailto:admin@teesvalleyrcc.org.uk)

💻 [www.teesvalleyrcc.org.uk](http://www.teesvalleyrcc.org.uk)

## County Durham

### Durham Community Action

Executive Director: Joanna Laverick

8 St Stephen's Court, Low Willington Industrial  
Estate, Willington, Crook, County Durham,  
DL15 0BF

☎ 01388 742040

✉ [info@durhamrcc.org.uk](mailto:info@durhamrcc.org.uk)

💻 [www.durhamrcc.org.uk](http://www.durhamrcc.org.uk)

### East Durham Trust

Chief Executive Officer: Malcolm Fallow

Community House, Yoden Road, Peterlee,  
County Durham, SR8 5DP

☎ 0191 569 3511

✉ [Malcolm.fallow@eastdurhamtrust.org.uk](mailto:Malcolm.fallow@eastdurhamtrust.org.uk)

💻 [www.eastdurhamtrust.org.uk](http://www.eastdurhamtrust.org.uk)

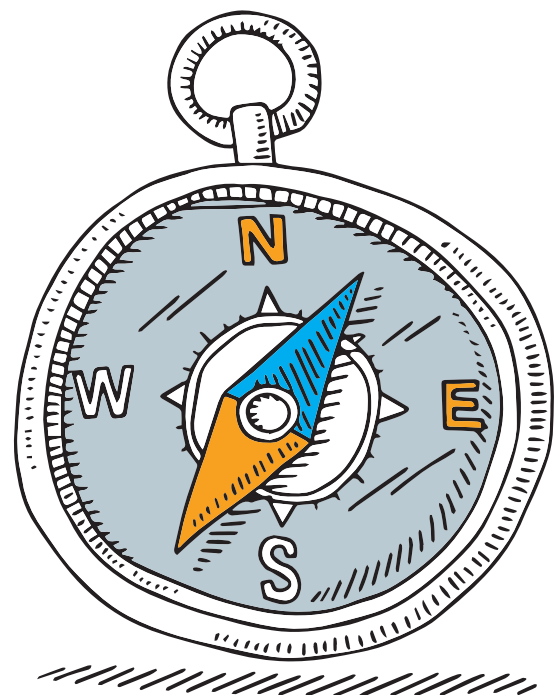



# Volunteer Centres

## Tyne and Wear

### Volunteer Centre North Tyneside

The Shiremoor Centre, Earsdon Road, Shiremoor,  
Tyne & Wear, NE27 0HJ

 0191 643 2634

 volunteering@voda.org.uk

 www.voda.org.uk/cms/volunteering

### Volunteer Centre Newcastle

Broadacre House, Market Street, Newcastle upon  
Tyne, Tyne & Wear, NE1 6HQ

 0191 338 9696

 vcnewcastle@yahoo.co.uk

 www.volunteercentrenewcastle.org.uk

### Voluntary and Community Action Sunderland

8 Frederick Street, Sunderland, Tyne & Wear,  
SR1 1NA

 0191 565 1566

 volunteering@vcas.org.uk

 www.vcasunderland.org.uk/volunteering

## Northumberland

### Volunteering Northumberland

109 Station Road, Ashington, Northumberland,  
NE63 8RS

 01670 858 688

 enquire@northumberlandcva.org.uk

 www.northumberlandcva.org.uk/volunteering

## Tees Valley

### Volunteer Centre Middlesbrough

St Mary's Centre, 82-90 Corporation Road,  
Middlesbrough, TS1 2RW

 01642 803 613

 general@mvdauk.org.uk

 www.mvda.info/volunteering

### RCVDA Volunteer Centre

Westfield Farm, The Green, Dormanstown,  
TS10 5NA

 01642 440 571

 enquiries@rcvda.org.uk

 www.rcvda.org.uk/volunteering

## County Durham

### Durham Community Action

8 St Stephen's Court, Low Willington, Crook,  
County Durham, DL15 0BF

 01388 742040

 info@durhamrcc.org.uk

 www.durhamrcc.org.uk

### East Durham Trust

Community House, Yoden Road, Peterlee  
County Durham, SR8 5DP

 0191 5693511

 colin.jackson@eastdurhamtrust.org.uk

 www.eastdurhamtrust.org.uk



# Key North East Funders

Grant funding provides a major contribution to the voluntary and community sector. Here we show some of the major North East funders and attempt to give an overall picture of the funding spend in the North East.

The figures given here should only be seen as indicative. We are not trying to rank the different funders. Indeed, it is not possible to make a direct comparison between the funders as different funders account for their grants in different ways and the figures cover varied time periods.

## Big Lottery Fund

2 St. James Gate, Newcastle upon Tyne NE1 4BE

Telephone: 0191 376 1600

 [www.biglotteryfund.org.uk](http://www.biglotteryfund.org.uk)

 [general.enquiries@biglotteryfund.org.uk](mailto:general.enquiries@biglotteryfund.org.uk)

Grants given in North East from April–Oct 2016:  
378

Total value: £24,765,116

The Big Lottery Fund is responsible for giving out half the money raised for good causes by the National Lottery. It works to bring real improvements to communities and the lives of people in need. Funding is focused on: supporting community learning and creating opportunity; promoting community safety and cohesion; promoting well-being.

## Community Foundation, Tyne and Wear and Northumberland

Philanthropy House, Woodbine Road, Newcastle upon Tyne NE3 1DD

 0191 222 0945

 [general@communityfoundation.org.uk](mailto:general@communityfoundation.org.uk)

 [www.communityfoundation.org.uk](http://www.communityfoundation.org.uk)

Grants given in 2014/15: 1355 (740 organisations)

Total value: £5.4m

The Foundation aims to strengthen communities and enrich local life by inspiring and supporting effective giving. It ensures the generosity of individuals, families, businesses and charities is matched with excellent groups and individuals that bring people together, provide great services and activities and make our area a better place to enjoy life. It supports a wide variety of community causes and activities.

## The Coalfields Regeneration Trust

1 Waterside Park, Valley Way, Wombwell, Barnsley S73 0BD

Contact: Stephen Abson, Development Manager

Contact: Lynn Utting, Development Manager

 01226 272818

 01226 272829

 [stephen.abson@coalfields-regen.org.uk](mailto:stephen.abson@coalfields-regen.org.uk)

 [lynn.utting@coalfields-regen.org.uk](mailto:lynn.utting@coalfields-regen.org.uk)

 [www.coalfields-regen.org.uk](http://www.coalfields-regen.org.uk)

The Coalfields Regeneration Trust (CRT) is the leading regeneration organisation dedicated to improving the quality of life in Britain's former mining communities. CRT is a charitable company and social enterprise with teams deployed across England, Scotland and Wales. CRT's mission is to champion coalfield communities, generate resources to respond to their needs and deliver programmes that make a positive and lasting difference.

## Lloyds Bank Foundation

Pentagon House, 52-54 Southwark Street, London SE1 1UN

 0370 411 1223

 [www.lloydsbankfoundation.org.uk](http://www.lloydsbankfoundation.org.uk)

Contact: Louise Telford, Grant Manager, North East and Cumbria

 [ltelford@lloydsbankfoundation.org.uk](mailto:ltelford@lloydsbankfoundation.org.uk)

Grants given to North East in 2014 - 2015: 649

Total value: £1.7m

The Foundation makes grants to recognised charities that help people, especially those who are disadvantaged, to play a fuller role in their communities. They accept applications from all sections of the community and especially from small, under-funded charities.

# Key North East Funders

## BBC Children in Need

PO Box 649, Salford M5 0LD

☎ 0345 609 0015 (General)  
☎ 0191 232 1313 (North East)  
💻 pudseygrants@bbc.co.uk  
✉ www.bbc.co.uk/pudsey

BBC Children in Need raises money to help disadvantaged children and young people across the UK and change their lives for the better. They have a general grants programme as well as separate strands focusing on particular aims or areas of disadvantage.

Grants given to North 2014/15: 281

Total value: £11.5m

## County Durham Community Foundation

Victoria House, Whitfield Court, St John's Road, Meadowfield Industrial Estate, Durham, DH7 8XL

☎ 0191 378 6340  
✉ info@cdcf.org.uk  
💻 www.cdcf.org.uk

Grants given in 2015/16: 649

Total value: £1.7m

The Foundation aims to improve the quality of life for people in County Durham and Darlington by channelling funds to grass roots communities. Grants are made to voluntary and community groups that can show real community support and demonstrable benefits.

## Tees Valley Community Foundation

Tees Valley Community Foundation, Wallace House, Falcon Court, Preston Farm, Stockton-on-Tees, TS18 3TX

Contact: Hugh McGowan

☎ 01642 260 860  
✉ info@teesvalleyfoundation.org  
💻 www.teesvalleyfoundation.org

Grants given in 2014/15: 217

Total value: £538,704

The Foundation aims to improve the quality of life for people in the Tees Valley. It supports grassroots community groups and projects with the aim of alleviating all forms of disadvantage.

## Comic Relief

UK Grants Manager, 89 Albert Embankment, London SE1 7TP

☎ 020 7820 2000  
✉ info@comicrelief.com  
💻 www.comicrelief.com

Grants given in 2014-2015: 178

Total value: £1.4m

Comic Relief aims to deliver change to the poorest, most vulnerable people in the UK and across the world. Funding is made across four key areas: Investing in children and young people, Empowering women and girls, Improving health and wellbeing, and Building stronger communities.

## Sherburn House Charity

Sherburn Hospital, Durham DH1 2SE

☎ 0191 372 2551  
✉ info@sherburnhouse.org  
💻 www.sherburnhouse.org

The priorities of the charity are the relief of need, hardship and distress in the North East of England. The charity distributes grants to organisations of generally up to £5,000. It operates in the region north of Tees to the River Tweed.

Grants given in 2015/16: 82

Total value: £252,563

## Greggs Foundation

Quorum Business Park, Newcastle Upon Tyne  
NE12 8BU

0191 212 7626

greggsfoundation@greggs.co.uk

www.greggsfoundation.org.uk

Grants value 2015: £2.01m including £405,015 in  
North East Core Funding

The Greggs Foundation is a registered charity closely associated with Greggs plc. The Greggs Foundation is a grant making trust, distributing over £1million per year to charitable organisations throughout England, Scotland and Wales. Its mission is to 'make a difference to the lives of people in need in the heart of our local communities'.

## Esmée Fairbairn Foundation

Kings Place, 90 York Way, London. N1 9AG

020 7812 3700

info@esmeefairbairn.org.uk

www.esmeefairbairn.org.uk

Grants given in 2015: 307

Total Value: £33.6m

Esmée Fairbairn Foundation is one of the largest independent grant-making foundations in the UK. The Foundation's main interests are in the Arts, children and young people, the environment and social change. It makes grants of around £35m each year plus social investments of up to £35m

## Millfield House Foundation

Minstrel's House, West Marlish, Morpeth,  
Northumberland NE61 4ER

Contact: Fiona Ellis

fiona.ellis@mhfdn.org.uk

www.mhfdn.org.uk

Grants given in 2014/15: £206,409

The current priority is to promote social change by funding projects that inform discussion and influence public policy, with the aim of empowering communities and reducing social deprivation.

The Foundation does not accept unsolicited applications.

## Garfield Weston

Weston Centre, 10 Grosvenor Street, London  
W1K 4QY

Contact: Lisa Friel

frcraig@garfieldweston.org.uk

www.garfieldweston.org

Grants given in 2015-16: 109

Garfield Weston Foundation is a family-founded, grant-making trust and since it was established in 1958 the Foundation has given over £900million to charities across the UK. In the last year alone the Foundation donated over £58million. From small community groups to large national institutions, the Foundation supports a broad range of organisations and activities that make a positive impact in the communities in which they work. Over 1,600 charities across the UK benefit each year from the Foundation's grants and the Trustees are especially keen to receive applications from charities in the North East as one of their priority areas.

## Ballinger Charitable Trust

PO Box 166, Ponteland, Newcastle Upon Tyne  
NE20 2BL

Contact: Mrs J Douthwaite

0191 488 0520

info@ballingercharitabletrust.org.uk

www.ballingercharitabletrust.org.uk

Grants given in 2014: 92

Total value: £1.46m

The Ballinger Charitable Trust was founded in 1994 and seeks to support charities, voluntary organisations and community groups through grants and funding.

The focus on the Trust is currently to support projects in the North East principally by providing funds that support the health, development and wellbeing of young people, support the elderly and/or promote cultural/arts projects based in the region.

# Key North East Funders

## Sir James Knott Trust

Sir James Knott Trust, 16-18 Hood Street,  
Newcastle upon Tyne NE1 6JQ.

Contact: Mrs V R Stapley

☎ 0191 230 4016

✉ info@knott-trust.co.uk

🌐 www.knott-trust.co.uk

Grants given in 2014-2015: 323

Total value: £1.2m

Sir James Knott Trust is an independent, grant making charitable trust based in Newcastle upon Tyne. The Trust supports community projects in the North East to help improve the conditions of people living and working in the region.

## Virgin Money Foundation

Jubilee House, Gosforth, Newcastle Upon Tyne  
NE3 4PL

☎ 0191 279 6789

✉ info@virginmoneyfoundation.org.uk

🌐 www.virginmoneyfoundation.org.uk

Grants given in 2015: 27

Total value: £1m

The Foundation makes grants primarily through its North East Fund, a rolling grants programme aiming to help community organisations working to promote long-term change in the most deprived communities in the North East.

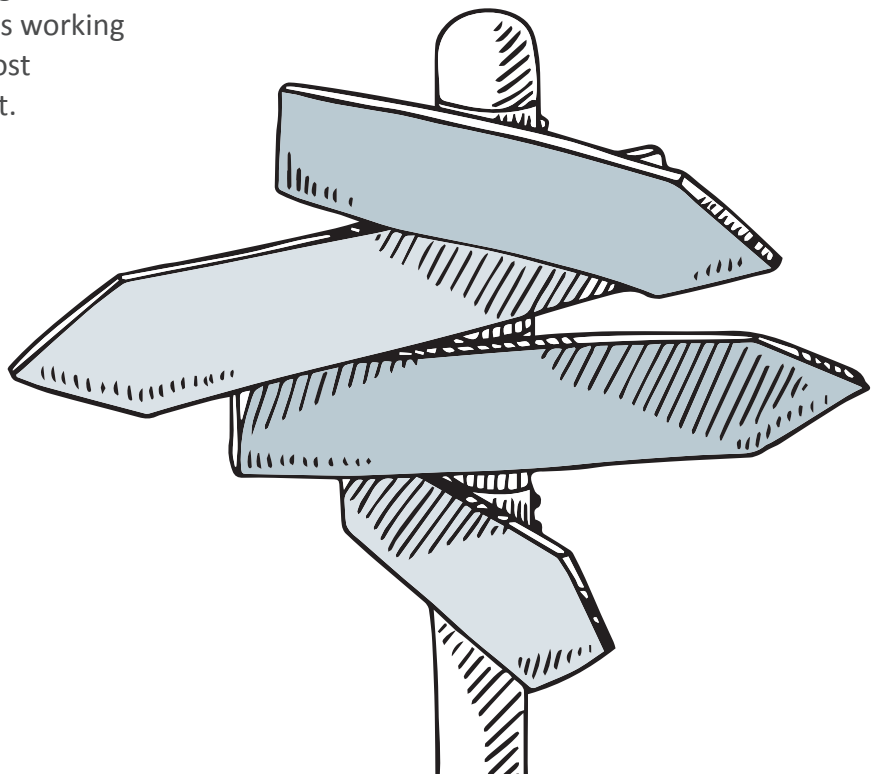

# Local authorities and their VCSE leads

## Darlington Borough Council

Town Hall, Darlington DL1 5QT

01325 380 651

01325 382 032

enquiries@darlington.gov.uk

www.darlington.gov.uk



**Leader:** Councillor Bill Dixon (Labour)

**Chief Executive:** Ada Burns

**VCSE contact:** Natasha Telfer

natasha.telfer@darlington.gov.uk

## Hartlepool Borough Council

Civic Centre, Hartlepool TS24 8AY

01429 266 522

01429 523 005

customer.services@hartlepool.gov.uk

www.hartlepool.gov.uk



**Leader:** Councillor Christopher Akers-Belcher (Labour)

**Chief Executive:** Gill Anderson

**VCSE contact:** Tracy Rowe

tracy.rowe@hartlepool.gov.uk

## Durham County Council

County Hall, Durham DH1 5UL

0300 123 7070

0191 383 4500

help@durham.gov.uk

www.durham.gov.uk



**Leader:** Councillor Simon Henig (Labour)

**Chief Executive:** Terry Collins

**VCSE contact:** Ian Hunter Smart

ian.huntersmart@durham.gov.uk

## Middlesbrough Council

PO Box 99A, Town Hall, Middlesbrough TS1 2QQ

01642 245 432

01642 263 827

contactcentre@middlesbrough.gov.uk

www.middlesbrough.gov.uk



**Elected Mayor:** Mr Dave Budd (Independent)

**Chief Executive:** Tony Parkinson

**VCSE contact:** Sharon Barker

sharon\_barker@middlesbrough.gov.uk

## Gateshead Council

Civic Centre, Regent Street, Gateshead, NE8 1HH

0191 433 3000

0191 478 3495

enquiries@gateshead.gov.uk

www.gateshead.gov.uk



**Leader:** Councillor Martin Gannon (Labour)

**Acting Chief Executive:** Mike Barker

**VCSE contact:** Linda Whitfield

lindawhitfield@gateshead.gov.uk

## Newcastle City Council

Civic Centre, Newcastle upon Tyne, NE1 8QH

0191 278 7878

csc@newcastle.gov.uk

www.newcastle.gov.uk



**Leader:** Councillor Nick Forbes (Labour)

**Chief Executive:** Pat Ritchie

**VCSE contact:** Adam Taeger

adam.taeger@newcastle.gov.uk

# Local authorities and their VCSE leads

## North Tyneside Council

Quadrant, The Silverlink, North Cobalt Business Park, North Tyneside, NE27 0BY

 0845 200 0101



North Tyneside Council

 [contact.us@northtyneside.gov.uk](mailto:contact.us@northtyneside.gov.uk)

 [www.northtyneside.gov.uk](http://www.northtyneside.gov.uk)

**Elected Mayor:** Norma Redfearn (Labour)

**Chief Executive:** Patrick Melia

**VCSE contact:** Felicity Shoesmith

 [felicity.shoesmith@northtyneside.gov.uk](mailto:felicity.shoesmith@northtyneside.gov.uk)

## South Tyneside Council

Town Hall & Civic Offices, Westoe Road, South Shields. NE33 2RL

 0191 427 7000

 0191 455 0208



South Tyneside Council

 [customerhelp@southtyneside.gov.uk](mailto:customerhelp@southtyneside.gov.uk)

 [www.southtyneside.gov.uk](http://www.southtyneside.gov.uk)

**Leader:** Councillor Iain Malcolm (Labour)

**Chief Executive:** Martin Swales

**VCSE contact:** Angi Rimington

 [angi.rimington@southtyneside.gov.uk](mailto:angi.rimington@southtyneside.gov.uk)

## Northumberland County Council

County Hall, Morpeth, Northumberland NE61 2EF

 0345 600 6400

 [ask@northumberland.gov.uk](mailto:ask@northumberland.gov.uk)

 [www.northumberland.gov.uk](http://www.northumberland.gov.uk)



Northumberland County Council

**Leader:** Councillor Grant Davey (Lab)

**Executive Director:** Steven Mason

**VCSE contact:** Kirsten Francis

 [kirsten.francis@northumberland.gov.uk](mailto:kirsten.francis@northumberland.gov.uk)

## Stockton-on-Tees Borough Council

Municipal Buildings, Church Road, Stockton-on-Tees TS18 1LD

 01642 393 939

 01642 393 092



Stockton-on-Tees  
BOROUGH COUNCIL

 [customer.comments@stockton.gov.uk](mailto:customer.comments@stockton.gov.uk)

 [www.stockton.gov.uk](http://www.stockton.gov.uk)

**Leader:** Councillor Bob Cook (Labour)

**Chief Executive:** Neil Schneider

**VCSE contact:** Laurayne Featherstone

 [laurayne.featherstone@stockton.gov.uk](mailto:laurayne.featherstone@stockton.gov.uk)

## Redcar and Cleveland Borough Council

Town Hall, PO Box 8, Fabian Road, South Bank, TS6 9AR

 01642 774 774

 01642 440 599

 [memberservices@redcar-cleveland.gov.uk](mailto:memberservices@redcar-cleveland.gov.uk)

 [www.redcar-cleveland.gov.uk](http://www.redcar-cleveland.gov.uk)



**Leader:** Councillor Sue Jeffrey (Labour)

**Chief Executive:** Amanda Skelton

**VCSE contact:** Adrian Harris

 [adrian.harris@redcar-cleveland.gov.uk](mailto:adrian.harris@redcar-cleveland.gov.uk)

## Sunderland City Council

PO Box 100, Civic Centre, Sunderland, SR2 7DN

 0191 520 5555

 0191 553 1020



 [customerservicesnetwork@sunderland.gov.uk](mailto:customerservicesnetwork@sunderland.gov.uk)

 [www.sunderland.gov.uk](http://www.sunderland.gov.uk)

**Leader:** Councillor Paul Watson (Labour)

**Chief Executive:** Dave Smith

**VCSE contact:** Charlotte Burnham

 [charlotte.burnham@sunderland.co.uk](mailto:charlotte.burnham@sunderland.co.uk)



# Key public sector contacts in the North East

Here we present a list of the key public sector agencies and contacts in the North East involved in policy. Whitehall and central Government operate in the North East in new ways since the major changes to regional institutions brought about by the previous Coalition government. A number of senior staff, with a base in Whitehall departments, work in the North East. The Conservative government is moving towards devolving power further to city areas through its 'devolution' agenda. These contacts all have influence over how the region develops and are important contacts for the VCSE sector.

## North East Combined Authority

**Chair:** Cllr Paul Watson

**Interim Head of Paid Service:** Helen Golightly

NECA Quadrant, Cobalt Business Park, Silverlink North, North Tyneside, NE27 0BY

 [www.neca.co.uk](http://www.neca.co.uk)

The North East Combined Authority (NECA), established in 2014, is a legal body that brings together the seven councils which serve County Durham, Gateshead, Newcastle, North Tyneside, Northumberland, South Tyneside and Sunderland. Together they have put together a case for a single, politically accountable body for the area, which could access devolved powers to stimulate economic growth, job creation, skills development and improved transport links.

Currently there is representation for the VCSE to the Combined Authority through the NECA Employability, Inclusion and Skills Steering Group.

**Areas of Influence:** Transport, employability/inclusion, economic development, skills

## Tees Valley Combined Authority

**Chair:** Mayor David Budd

**Managing Director:** Andrew Lewis

 [www.teesvalley-ca.gov.uk](http://www.teesvalley-ca.gov.uk)

The Tees Valley Combined Authority (TVCA) is a statutory body for Tees Valley. The five local authorities, Darlington, Hartlepool, Middlesbrough, Redcar & Cleveland and Stockton unite under the Combined Authority to make decisions on key strategies relating to economic development, transport, infrastructure and skills. It creates a single voice for the area on these key matters, providing greater power and resources for the Tees Valley area.

**Areas of influence:** Economic development, transport, infrastructure and skills.



# Key public sector contacts in the North East

## Local Economic Partnerships

In the North East we have two Local Enterprise Partnerships (LEPs) that between them cover the whole of the North East region. The LEPs are charged with stimulating economic growth in the region. Each LEP is responsible for developing and implementing Strategic Economic Plans and European Structural Fund Plans. Both boards are made up of public/private sector partnerships including business, council and higher education leaders.

Whilst there is no designated place on each board specifically for the VCSE, both heads are keen to work with the sector in driving forward the economy. Areas of influence include economic growth, regeneration, skills, employment, transport and infrastructure..

## North East Local Enterprise Partnership (NELEP)

The North Eastern LEP, covers the 7 local authority areas of County Durham, Gateshead, Newcastle, North Tyneside, Northumberland, South Tyneside and Sunderland.

The North East LEP has set a strategy for economic growth through the North East Strategic Economic Plan. It details how NELEP will work with partners, businesses and communities to allow them to implement the Plan's ambitions.

 [www.nelep.co.uk](http://www.nelep.co.uk)

**Chief Operating Officer:** Helen Golightly

 0191 338 7422

 [helen.golightly@nelep.co.uk](mailto:helen.golightly@nelep.co.uk)

**Chair:** Andrew Hodgson, Chief Executive of subsea engineering specialist SMD in North Tyneside

**Vice Chair:** Cllr Paul Watson, Leader of Sunderland City Council

## Tees Valley Local Enterprise Partnership

Tees Valley Unlimited is the Tees Valley LEP which includes five Local Authorities - Darlington, Hartlepool, Middlesbrough, Redcar and Cleveland and Stockton on Tees. It has now combined with Tees Valley Unlimited, the Combined Authority for the area.

 [www.teesvalley-ca.gov.uk](http://www.teesvalley-ca.gov.uk)

 [info@teesvalley-ca.gov.uk](mailto:info@teesvalley-ca.gov.uk)

**Chair:** Paul Booth OBE, President of SABIC UK

## Homes & Communities Agency

**Acting Director:** Naz Parker

Contact details: St. George's House, Kingsway, Team Valley, Gateshead, NE11 0NA

 0300 123 4500

 [www.gov.uk/government/organisations/homes-and-communities-agency](http://www.gov.uk/government/organisations/homes-and-communities-agency)

The Homes and Communities Agency is the national housing and regeneration delivery agency for England. Its role is to create thriving communities and affordable homes. It works nationally but supports the ambitions of local partners to provide better places that offer great homes and good jobs.

**Areas of Influence:** Affordable housing, regeneration.

## Jobcentre Plus

**Regional contact:** Steven Martin, External Relations Manager

✉ [steve.martin3@jobcentreplus.gsi.gov.uk](mailto:steve.martin3@jobcentreplus.gsi.gov.uk)

Jobcentre Plus, North East England, 1 Cathedral Square , Moseley Street, Newcastle upon Tyne, NE1 1EE

☎ 0345 604 3719

✉ [www.dwp.gov.uk](http://www.dwp.gov.uk)

In the North East, Jobcentre Plus works with a wide range of partners to deliver services to help their customers. Their Regional and District External Relations managers work with organisations with mutual aims to help their customers into work, improve the regions skills base, and provide support to meet customer needs, including developing specialist support for disadvantaged client groups.

**Areas of Influence:** Skills, employability, reducing worklessness, pathways to work.

## Senior Government Staff in the North East

### Department for Business Innovation and Skills

Isobel Mills, Director of BIS Local Team

✉ [isobel.mills@bis.gsi.gov.uk](mailto:isobel.mills@bis.gsi.gov.uk)

Isobel is the director of BIS Yorkshire Humber and North East, one of six small teams set up to ensure direct links are maintained with local areas and to provide information from on the ground. Their work includes leading BIS relationships with Local Enterprise Partnerships and local government; assisting coordination of economic development delivery and helping partnerships build their capacity and capability.

The team support BIS Ministers including briefing and visits and maintains strong links with businesses, key sectors and local business bodies, to build local understanding and buy-in to BIS policies, feeding back local intelligence that influences and contributes to the development of new policies.

**Alternative contact:** [sue.price@bis.gsi.gov.uk](mailto:sue.price@bis.gsi.gov.uk)

## Cabinet Office

Paul Schofield, Senior Policy Advisor, Local Intelligence Team, Cabinet Office

✉ [paul.schofield@cabinetoffice.gov.uk](mailto:paul.schofield@cabinetoffice.gov.uk)

The Local Intelligence Team share intelligence and innovation on building the Big Society. The team provide local partners with information about local and national policy and programmes relating to the Big Society. It feeds intelligence on local innovation, local successes and problems into the development of local and national policy.

# Key public sector contacts in the North East

## Department for Environment, Food and Rural Affairs

Andy Tordoff, Head of Rural Development Programme England Delivery Team Yorkshire & North East

✉ [Andy.tordoff@defra.gsi.gov.uk](mailto:Andy.tordoff@defra.gsi.gov.uk)

## Department for Transport

Margaret Jackson, Head of Northern Engagement Team

✉ [Margaret.Jackson@dft.gsi.gov.uk](mailto:Margaret.Jackson@dft.gsi.gov.uk)

## ERDF Programme Manager, North East and Yorkshire, Humber

Raffaella Ebani, Growth Delivery Team

✉ [raffaella.ebani@communities.gsi.gov.uk](mailto:raffaella.ebani@communities.gsi.gov.uk)

## Association of Colleges

Gillian Miller - Regional Director

AoC North East Office, Room 126, Regus House, Doxford International Business Park, Sunderland, SR3 3XW

☎ 0191 501 8573

✉ [gillian\\_miller@aoc.co.uk](mailto:gillian_miller@aoc.co.uk)

🌐 [www.aoc.co.uk/about-us/aoc-regions/aoc-north-east](http://www.aoc.co.uk/about-us/aoc-regions/aoc-north-east)

The Association of Colleges (AoC) exists to represent and promote the interests of Colleges and provide members with professional support services. AoC's North East region has 20 member colleges. They help their member colleges to deliver social and economic benefit to people, businesses and communities on the ground.

## Skills Funding Agency

Moongate House, 5th Avenue, Team Valley Trading Estate, Gateshead, Tyne and Wear , NE11 0HF

☎ 0845 019 4181

**Deputy Director:** Nick Wilson, North East and Yorkshire

✉ [nick.wilson@sfa.bis.gov.uk](mailto:nick.wilson@sfa.bis.gov.uk)

☎ 0191 492 6372

The Skills Funding Agency funds skills training for further education (FE) in England. It supports over 1,000 colleges, private training organisations, and employers with more than £4 billion of funding each year. SFA is an executive agency, sponsored by the Department for Business, Innovation & Skills.

# North East Members of Parliament



Follow our Twitter list of North East MPs to see them all: [www.twitter.com/VONNENews/lists/north-east-mps](https://www.twitter.com/VONNENews/lists/north-east-mps)

<b>Berwick-upon-Tweed</b>	Anne-Marie Trevelyan (C) trevelyanoffice@gmail.com	@AnnieTrev
<b>Blyth Valley</b>	Ronnie Campbell (LAB) ronnie.campbell.mp@parliament.uk	
<b>Bishop Auckland</b>	Helen Goodman (LAB) goodmanh@parliament.uk	@HelenGoodmanMP
<b>Blaydon</b> Shadow Secretary of State for Scotland and for Northern Ireland	Dave Anderson (LAB) andersonda@parliament.uk	@DaveAndersonMP
<b>Darlington</b>	Jenny Chapman (LAB) mail@roberta.org.uk	@JennyChapman
<b>Durham City</b> Shadow Minister for Local Government and Housing	Roberta Blackman-Woods (LAB) woods@parliament.uk	@robertabwMP
<b>Durham North</b> Shadow Minister for Defence	Kevan Jones (LAB) kevanjonesmp@parliament.uk	@KevanJonesMP
<b>Durham North West</b> Shadow Transport Minister (Rail)	Pat Glass (LAB) pat.glass.mp@parliament.uk	@PatGlassMP
<b>Easington</b> Shadow Secretary of State for Communities and Local Government	Grahame Morris (LAB) grahame.morris.mp@parliament.uk	@grahamemorris
<b>Gateshead</b>	Ian Mearns (LAB) ian.mearns.mp@parliament.uk	@IanMearnsMP
<b>Hartlepool</b> Chair of Business, Energy and Industrial Strategy Select Committee	Iain Wright (LAB) wrighti@parliament.uk	@IainWrightMP
<b>Hexham</b>	Guy Opperman (C) guy.opperman.mp@parliament.uk	@GuyOppermanMP
<b>Houghton and Sunderland South</b>	Bridget Phillipson (LAB) bridget.phillipson.mp@parliament.uk	@bphillipsonMP
<b>Jarrow</b>	Stephen Hepburn (LAB) hepburns@parliament.uk	@jarrowstevemp
<b>Middlesbrough</b> Shadow Secretary of State for Transport	Andy McDonald (LAB) info@andymcdonaldmp.org	@AndyMcDonaldMP
<b>Middlesbrough South and East Cleveland</b>	Tom Blenkinsop (LAB) info@tomblenkinsop.com	@TomBlenkinsop
<b>Newcastle upon Tyne North</b> Shadow Attorney General	Catherine McKinnell (LAB) catherine.mckinnell.mp@parliament.uk	@CatMcKinnellMP
<b>Newcastle upon Tyne Central</b> Shadow Minister for Industrial Strategy	Chi Onwurah (LAB) chi.onwurah.mp@parliament.uk	@ChiOnwurah

# North East Members of Parliament



<b>Newcastle upon Tyne East</b>	Nick Brown (LAB)	
<b>North Tyneside</b>	Mary Glendon (LAB) mary.glendon.mp@parliament.uk	
<b>Redcar</b>	Anna Turley (Lab)	@AnnaTurley
<b>Sedgefield</b>	Phil Wilson (LAB)	@PhilWilsonMP
<b>South Shields</b> Shadow Minister for Children & Families	Emma Lewell-Buck (LAB)	@EmmaLewellBuck
<b>Stockton North</b>	Alex Cunningham (LAB)	@ACunninghamMP
<b>Stockton South</b> Parliamentary Under-Secretary of State (Department for International Development)	James Wharton (C)	
<b>Sunderland Central</b> Chair of Labour Backbench Cmte on Housing	Julie Elliott (LAB) julie.elliott.mp@parliament.uk	@JulieElliottMP
<b>Tynemouth</b> Opposition Deputy Chief Whip (Commons)	Alan Campbell (LAB)	@alancampbellmp
<b>Wansbeck</b>	Ian Lavery (LAB)	@IanLaveryMP
<b>Washington and Sunderland West</b> Shadow Minister for Public Health	Sharon Hodgson (LAB)	@SharonHodgsonMP

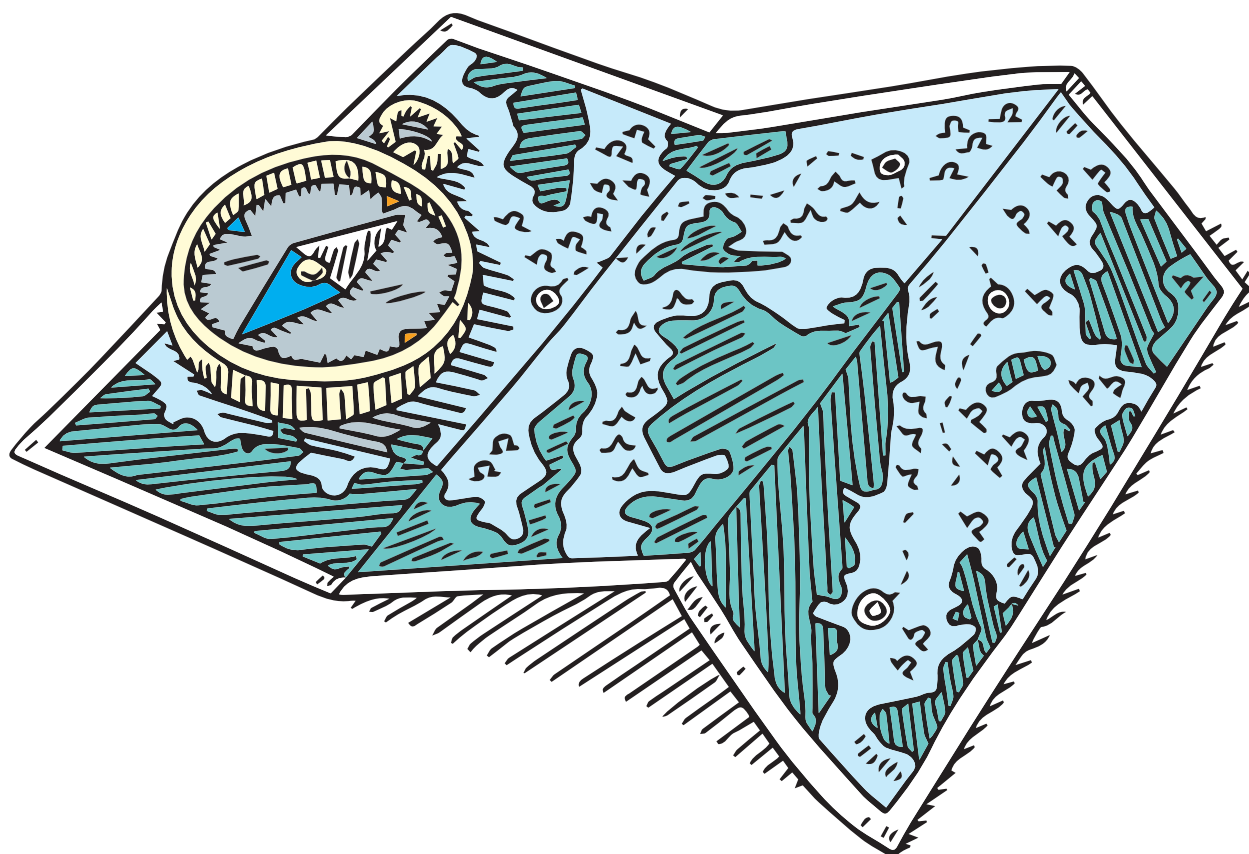

# North East MPs

There are 73 UK MEPs. They are elected in Great Britain and Northern Ireland. Other EU member states elect MEPs from their countries. Elections take place every five years so the next elections will be in 2019.

The UK is divided into 12 electoral regions made up of the nations and regions of the UK. Each region has between three and ten MEPs and each MEP in a region represents each person living there. In the North East there are three MEPs. For example, if you live in Newcastle, all three North East region MEPs represent you and you can contact any or all of them.

## Paul Brannen

Group of the Progressive Alliance of Socialists and Democrats  
in the European Parliament  
Constituency: North East  
National party: Labour Party



### Committees

Member: Committee on Agriculture and Rural Development  
Substitute: Committee on Environment, Public Health and Food Safety

✉ [office@northeastlabour.eu](mailto:office@northeastlabour.eu)  
💻 [www.labour4ne.org.uk/paul\\_brannen](http://www.labour4ne.org.uk/paul_brannen)

## Jonathan Arnott

Europe of Freedom and Direct Democracy group  
Constituency: North East  
National party: United Kingdom Independence Party (UKIP)



### Committees

Member: Committee on Budgets, Committee on Budgetary Control

✉ [jonathan.arnott@ep.europa.eu](mailto:jonathan.arnott@ep.europa.eu)  
💻 [www.jonathanarnott.co.uk](http://www.jonathanarnott.co.uk)

## Jude Kirton-Darling

Group of the Progressive Alliance of Socialists and Democrats in the  
European Parliament  
Constituency: North East  
National party: Labour Party



### Committees

Member: Committee on International Trade, Committee on Petitions  
Substitute: Committee on Industry, Research and Energy

✉ [office@northeastlabour.eu](mailto:office@northeastlabour.eu)  
💻 [www.labour4ne.org.uk/judith\\_kirton\\_darling](http://www.labour4ne.org.uk/judith_kirton_darling)

# Health and Wellbeing Landscape

## North of England Regional Team

NHS England North is one of four regional teams that support the commissioning of high quality services and directly commission primary care and specialised services. Geographically the North regional team covers Yorkshire and The Humber, the North-West and the North-East of England.

This includes providing support primarily to the Clinical Commissioning Groups (CCG's). They help by providing clinical and professional leadership, coordinating, planning, operational management and emergency preparedness. The regional team also works with other directorates to provide management and delivery of specialised commissioning, performance oversight and stakeholder engagement.

There are 68 clinical commissioning groups (CCGs) within the North region (211 nationally) who have responsibility for commissioning the majority of local health services for their populations. NHS England North works in partnership with these clinical commissioning groups as well as with Hospital Acute Trusts. You can find further information about them via the links below.

## North of England Regional Team

### Tim Rideout

Director of Commissioning Operations

✉ [t.rideout@nhs.net](mailto:t.rideout@nhs.net)

☎ 0113 8253314

### Audrey Pickstock

Director of Finance

✉ [Audrey.pickstock@nhs.net](mailto:Audrey.pickstock@nhs.net)

☎ 0113 825 1613

### Dr Jonathan Slade

Medical Director

✉ [d.slade@nhs.net](mailto:d.slade@nhs.net)

☎ 0113 825 3052

### Alison Slater

Director of Delivery

✉ [Alison.slater3@nhs.net](mailto:Alison.slater3@nhs.net)

☎ 011382 52981

### Bev Reilly

Director of Nursing

✉ [Bev.reilly@nhs.net](mailto:Bev.reilly@nhs.net)

☎ 01325 553056

### Christine Keen

Director of Commissioning

✉ [Christine.keen@nhs.net](mailto:Christine.keen@nhs.net)

☎ 0113 825 3052

## Cumbria and North East offices

Waterfront 4  
Goldcrest Way  
Newcastle upon Tyne  
NE15 8NY

☎ 0191 2106400

The Old Exchange  
Barnard Street  
Darlington  
Durham  
DL3 7DR

☎ 0113 8251600



## Public Health England

Public Health England (PHE) is an executive agency of the Department of Health with the aims of improving health, protecting health and reducing inequalities.

It has 9 local centres, one of which is the North East Centre and 4 regions, one of which is North of England. Each centre provides leadership and support across all three 'domains' of public health – health protection, health improvement and healthcare public health.

The Regional Office leads PHE's work with the new NHS England integrated regional/sub-regional teams, and the Centres lead the work to support Directors of Public Health in their local authorities' mandated function of working with Clinical Commissioning Groups, and the local NHS England commissioners, including the national NHS public health services. Regional Directors and Centre Directors together support local implementation of the Five Year Forward View.

### Public Health England North East Centre

**Centre Director:** Professor Peter Kelly

✉ [peter.kelly@phe.gov.uk](mailto:peter.kelly@phe.gov.uk)  
☎ 0300 303 8596 option 1

Floor 2 Citygate  
Gallowgate  
Newcastle upon Tyne  
NE1 4WH

### Public Health England North of England regional office

**Regional Director:** Paul Johnstone

✉ [paul.johnstone@phe.gov.uk](mailto:paul.johnstone@phe.gov.uk)  
☎ 0300 303 8395

Blenheim House  
West One  
Duncombe Street  
Leeds  
LS1 4PL

## North East Local Knowledge and Intelligence Service

The North East Local Knowledge and Intelligence Service (LKIS) is one of nine geographically distributed teams in Public Health England (PHE) that work with the regional PHE Centres. The aim of the service is to support effective local public action through the provision of high quality tools, products, expert advice and support. The local intelligence support includes training and workforce development, knowledge transfer and analysis through a locally tailored work programme.

LKIS North East can give you more information about health in your area.

✉ [LKISNorthEast@phe.gov.uk](mailto:LKISNorthEast@phe.gov.uk)

# Health and Wellbeing Landscape

## North East Directors of Public Health

**Public health** is the system of national, regional and local organisations, in local government, the NHS and Public Health England (PHE) which is responsible for protecting, promoting and improving the health and wellbeing of the population, including addressing health inequalities and the social, as well as the medical, determinants of health.

Since April 2013, many aspects of public health have moved from the NHS and become the responsibility of local authorities (those with responsibility for social care). Each local authority has a **Director of Public Health (DPH)** who is supported by a public health team. The DPH is a chief officer of the council and a statutory member of the local Health and Well-being Board. Local

councils now directly employ medically-qualified staff in their public health teams, as well as non-clinical public health specialists.

### Northumberland

**Director:** Penny Spring

✉ penny.spring@northumberland.gcsx.gov.uk

### North Tyneside

**Director:** Wendy Burke

✉ wendy.burke@northtyneside.org.uk

### Newcastle

**Director:** Eugene Milne

✉ eugene.milne@newcastle.gov.uk

### Gateshead

**Director:** Alice Wiseman

✉ alicewiseman@gateshead.gov.uk

### South Tyneside

**Director:** Amanda Healy

✉ amanda.healy@southtyneside.gov.uk

### Sunderland

**Director:** Gillian Gibson

✉ gillian.gibson@sunderland.gov.uk

### Durham

**Director:** Gillian O'Neill

✉ gillian.o'neill@durham.gov.uk

### Darlington

**Director:** Miriam Davidson

✉ miriam.davidson@darlington.gov.uk

### Stockton-on-Tees

**Director:** Sarah Bowman-Abouma

✉ sarah.bowman-abouma@stockton.gov.uk

### Hartlepool

**Director:** Louise Wallace

✉ louise.wallace@hartlepool.gov.uk

### Middlesbrough

**Director:** Edward Kunonga

✉ edward\_kunonga@middlesbrough.gov.uk

### Redcar & Cleveland

**Director:** Paul Edmondson-Jones

✉ paul.edmondson-jones@redcar-cleveland.gov.uk

## North East Health & Wellbeing Boards

Each local authority in the North East has its own Health and Wellbeing Board. These are relatively new structures, only operating with full powers and responsibilities from April 2013. The Boards are a forum where key leaders from the health and care systems can work together in partnership to improve the health and wellbeing of their local population. Boards should be the place where health services can co-ordinate with all the other services which shape people's health – notably social care, children's care, housing, employment, education and public health – to tackle the root causes of ill health and inequality. Boards should also provide a forum for challenge, discussion, and the involvement of local people and organisations.

Each Board is different, reflecting local decisions on membership, form and function. Some areas have built on established health partnerships. Others have set up new arrangements. However, all Boards are required to develop a shared understanding of the health and wellbeing needs of their local community, brought together in a Joint Strategic Needs Assessment (JSNA) and regularly updated. Using the JSNA, Boards are required to develop a joint Health and Wellbeing strategy as to how these needs can be best met. This should include recommendations for joint commissioning and integrating services across health and care services for the benefit of patients and the public. Boards are under a statutory duty to involve local people in the preparation of both the Joint Strategic Needs Assessment and the development of the joint Health and Wellbeing strategy.

Essentially, Board members should collaborate to understand their local community's needs, agree priorities and encourage commissioners to work in a more joined up way, whichever service they work for. Health and Wellbeing boards are expected to have strategic influence over commissioning decisions across all services which impact on health and wellbeing.

Boards are required by the Health and Social Care Act to have a minimum membership of one local elected councillor; a representative from the local Healthwatch; a representative of the local clinical commissioning group and the local authority directors of adult social services, children's services and public health. Boards are free to expand their membership to include a wide range of perspectives and expertise. Some have included representatives from the voluntary and community sector. Others have included Universities and Housing Associations.

However membership should not be the only way to engage with the work of the Board and all Boards are expected to ensure that the needs of local people as a whole are taken into account.

The tables over the page will take you to the website for each Health and Wellbeing Board. From there you can find both Joint Strategic Needs Assessment (JSNA) and the Health and Wellbeing strategy for your area.

We have also listed the current priorities for each of the 12 Health and Wellbeing Boards in the North East. The list is taken from the Local Government website. It is not a definitive list of all local activity but is intended to encourage collaborative working within and between each area. Your local Health and Wellbeing Strategy will provide much more detail on local action.

The details of Healthwatch representatives and Voluntary and Community Sector representatives have been taken from local contacts, Healthwatch websites and the most recent minutes and agenda of the Boards.

The Department of Health has produced a guide to Health & Wellbeing Boards. Regional Voices have prepared a guide on working with the voluntary and community sector for Health and Wellbeing Boards.

# Health and Wellbeing Landscape

## Northumberland Health and Wellbeing Board

Priorities in Northumberland include reducing alcohol related harm; tackling levels of obesity through diet and exercise; and promoting mental wellbeing.

 [www.northumberland.gov.uk/Care/Support/Health-wellbeing.aspx](http://www.northumberland.gov.uk/Care/Support/Health-wellbeing.aspx)

Chair	Councillor Sudan Dungworth
Healthwatch Representative	Cynthia Atkin (Healthwatch Chair)
VCS membership	None currently

## North Tyneside Health and Wellbeing Board

Priorities in North Tyneside include alcohol, cancer and mental health.

 [www.northtyneside.gov.uk](http://www.northtyneside.gov.uk)

Chair	Councillor Margaret Hall
Healthwatch Representatives	Peter Kenrick (Healthwatch Chair) Jenny McAteer (Healthwatch Officer)
VCS membership	D Titterton, Voluntary and Community Sector Chief Officer Group Alma Caldwell, Age UK North Tyneside

## Newcastle Wellbeing for Life Board

Newcastle's Wellbeing for Life Strategy includes areas of action such as working city, decent neighbourhoods, getting a good start in life, making wellbeing and health promotion a key dimension of all we do and maximising the wellbeing of people who have long term conditions.

 [www.wellbeingforlife.org.uk/wellbeing-life-board](http://www.wellbeingforlife.org.uk/wellbeing-life-board)

Chair	Councillor Nick Forbes
Healthwatch Representatives	Bev Bookless (Healthwatch Chair) Steph Edusei (Healthwatch Officer)
VCS membership	Sally Young, CEO, Newcastle Council for Voluntary Service Brendan Hill, VCS representative

## Gateshead Health and Wellbeing Board

Priorities in Gateshead are to ensure children have the best start in life; tackle the major causes of ill health through a focus on lifestyle risks and work with communities to improve emotional health and wellbeing.

 [www.gateshead.gov.uk/GSP/Meetings-and-Boards/Health-and-Wellbeing-Board-.aspx](http://www.gateshead.gov.uk/GSP/Meetings-and-Boards/Health-and-Wellbeing-Board-.aspx)

Chair	Councillor Lynne Caffrey
Healthwatch Representative	Douglas Bell (Healthwatch Chair)
VCS membership	Sally Young, Newcastle CVS

## South Tyneside Health and Wellbeing Board

Priorities in South Tyneside are reducing inequalities through prevention and early identification of risk; tackling youth unemployment; reducing social isolation in older people; improving the quality, integration and efficiency of local services

 [www.southtyneside.info](http://www.southtyneside.info)

Chair	Councillor Iain Malcolm
Healthwatch Representative	Sue Taylor (Healthwatch Chair)
VCS membership	None currently listed

## Sunderland Health and Wellbeing Board

Priorities in Sunderland are for a better start and strengthening families; economic leadership and development; and supporting older people to live independently.

 [www.sunderland.gov.uk/index.aspx?articleid=11237](http://www.sunderland.gov.uk/index.aspx?articleid=11237)

Healthwatch Representative	Kevin Morris (Healthwatch Chair)
VCS membership	None currently listed

## Durham Health and Wellbeing Board

Priorities in County Durham are tackling health inequalities, improving mental health and wellbeing and children's health.

 [www.countydurhampartnership.co.uk/article/8543/Health-and-Wellbeing-Board](http://www.countydurhampartnership.co.uk/article/8543/Health-and-Wellbeing-Board)

Chair	Councillor Lucy Hovvels
Healthwatch Representative	Judith Mashiter (Healthwatch Joint Chair)
VCS membership	None currently listed

## Darlington Health and Wellbeing Board

Priorities in Darlington include reducing health inequalities in cardiovascular disease, tackling alcohol related harm and improving mental health and wellbeing.

 [www.darlington.gov.uk](http://www.darlington.gov.uk)

Chair	Councillor Andy Scott
Healthwatch Representative	Michelle Thompson (Healthwatch Chair)
VCS membership	None currently listed

## Stockton Health and Wellbeing Board

Priorities in Stockton-on-Tees include giving every child the best start in life, preventing ill health and tobacco control.

 [www.stockton.gov.uk/healthandwellbeing/healthandwellbeingboard/](http://www.stockton.gov.uk/healthandwellbeing/healthandwellbeingboard/)

Chair	Councillor Jim Beall
Healthwatch Representative	Tony Beckwith (Healthwatch Chair)
VCS membership	None currently listed

# Health and Wellbeing Landscape

## Hartlepool Health and Wellbeing Board

Priorities in Hartlepool are to give every child the best start in life; enable all children and young people to maximise their capabilities and have control over their lives; enable all adults to maximise their capabilities and have control over their lives; create fair employment and good work for all; ensure healthy standard of living for all; create and develop healthy and sustainable places and communities; and to strengthen the role and impact of ill health prevention.

 [www.stockton.gov.uk/health-and-wellbeing/health-and-wellbeing-board/](http://www.stockton.gov.uk/health-and-wellbeing/health-and-wellbeing-board/)

Chair	Councillor Christopher Akers-Belcher
Healthwatch Representatives	Margaret Wrenn and Ruby Marshall
VCS membership	Tracy Woodhall

## Middlesbrough Health and Wellbeing Board

Middlesbrough prioritises improving health outcomes for children, tackling lifestyle risk factors (smoking, alcohol, obesity), tackling the social causes of poor health, improving emotional well-being and mental health across the life course.

 [www.middlesbroughpartnership.org.uk](http://www.middlesbroughpartnership.org.uk)

Chair	Councillor David Rudd
Healthwatch Representative	Dr Paul Crawshaw (Healthwatch Chair)
VCS membership	Vacant

## Redcar and Cleveland Health and Wellbeing Board

Priorities in Redcar and Cleveland are that children and young people have the best start in life; people in Redcar & Cleveland live healthier and longer lives; and that more people lead safe, independent lives.



 [www.redcar-cleveland.gov.uk](http://www.redcar-cleveland.gov.uk)

Chair	Sue Jeffrey
Healthwatch Representative	Dr Ian Holtby (Healthwatch Chair)
VCS membership	John Pearson



## North East NHS Clinical Commissioning Groups

There are currently ten Clinical Commissioning Groups in the North East.



### Northumberland

 [www.northumberlandccg.nhs.uk](http://www.northumberlandccg.nhs.uk)  
 [norccg.enquiries@nhs.net](mailto:norccg.enquiries@nhs.net)  
 01670 335 157



### North Durham

 [www.northdurhamccg.nhs.uk](http://www.northdurhamccg.nhs.uk)  
 [nduccg.northdurhamccg@nhs.net](mailto:nduccg.northdurhamccg@nhs.net)  
 0191 389 8600



### Newcastle and Gateshead

 [www.newcastlegatesheadccg.nhs.uk](http://www.newcastlegatesheadccg.nhs.uk)  
 [ngccg.enquiries@nhs.net](mailto:ngccg.enquiries@nhs.net)  
 0191 217 2996



### Durham Dales, Easington and Sedgfield

 [www.durhamdaleseasingtonsedgfieldccg.nhs.uk](http://www.durhamdaleseasingtonsedgfieldccg.nhs.uk)  
 [ddescg.enquiries@nhs.net](mailto:ddescg.enquiries@nhs.net)  
 0191 371 3222



### North Tyneside

 [www.northtynesideccg.nhs.uk](http://www.northtynesideccg.nhs.uk)  
 [contactus@northtynesideccg.nhs.uk](mailto:contactus@northtynesideccg.nhs.uk)  
 0191 293 1140



### Darlington

 [www.darlingtonccg.nhs.uk](http://www.darlingtonccg.nhs.uk)  
 [DARCCG.contact@nhs.net](mailto:DARCCG.contact@nhs.net)  
 01325 621414



### South Tyneside

 [www.southtynesideccg.nhs.uk](http://www.southtynesideccg.nhs.uk)  
 [STCCG@sotw.nhs.uk](mailto:STCCG@sotw.nhs.uk)  
 0191 283 1903



### Hartlepool and Stockton-on-Tees

 [www.hartlepoolandstocktonccg.nhs.uk](http://www.hartlepoolandstocktonccg.nhs.uk)  
 [hstccg.hartlepoolandstocktonccg@nhs.net](mailto:hstccg.hartlepoolandstocktonccg@nhs.net)  
 01642 745982

### Sunderland

 [www.sunderlandccg.nhs.uk](http://www.sunderlandccg.nhs.uk)  
 [SCCG@sotw.nhs.uk](mailto:SCCG@sotw.nhs.uk)  
 0191 512 8484

### South Tees

 [www.southteesccg.nhs.uk](http://www.southteesccg.nhs.uk)  
 [stccg.enquiries@nhs.net](mailto:stccg.enquiries@nhs.net)  
 01642 263030

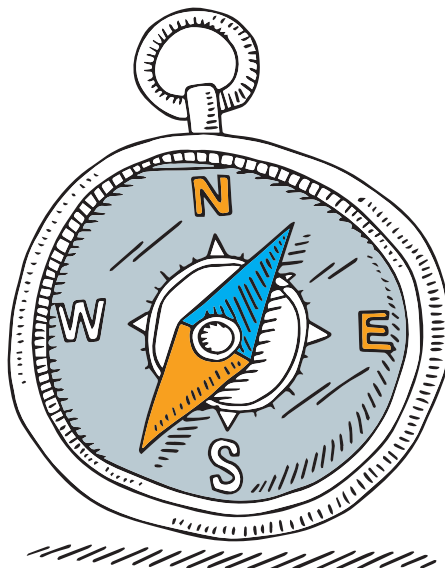









# Health and Wellbeing Landscape

## Local Authority Adult Social Care Services





### Northumberland

 [www.northumberland.gov.uk](http://www.northumberland.gov.uk)  
 [socialcare@northumbria.nhs.uk](mailto:socialcare@northumbria.nhs.uk)  
 01670 335 180



### North Tyneside

 [www.northtyneside.gov.uk](http://www.northtyneside.gov.uk)  
 [asc.team@northtyneside.gov.uk](mailto:asc.team@northtyneside.gov.uk)  
 0191 643 2777  
 SMS text message 07950 081 316



### Newcastle

 [www.newcastle.gov.uk/health-and-social-care/adult-social-care](http://www.newcastle.gov.uk/health-and-social-care/adult-social-care)  
 [scd@newcastle.gov.uk](mailto:scd@newcastle.gov.uk)  
 0191 643 2777  
 SMS text message 07950 081 316



### Gateshead

 [www.gateshead.gov.uk/Health-and-Social-Care/Adult-Social-Care/home.aspx](http://www.gateshead.gov.uk/Health-and-Social-Care/Adult-Social-Care/home.aspx)  
 [adultsocialcaredirect@gateshead.gov.uk](mailto:adultsocialcaredirect@gateshead.gov.uk)  
 0191 433 7033

### South Tyneside

 [www.southtyneside.gov.uk/article/174/People--care](http://www.southtyneside.gov.uk/article/174/People--care)  
 [adultsocialcare@southtyneside.gov.uk](mailto:adultsocialcare@southtyneside.gov.uk)  
 0845 130 4959



### Sunderland

 [www.sunderland.gov.uk/index.aspx?articleid=7820](http://www.sunderland.gov.uk/index.aspx?articleid=7820)  
 [enquiries@sunderland.gov.uk](mailto:enquiries@sunderland.gov.uk)  
 0191 520 5552



### Durham

 [www.durham.gov.uk/article/2316/Adult-Care](http://www.durham.gov.uk/article/2316/Adult-Care)  
 [scd@durham.gov.uk](mailto:scd@durham.gov.uk)  
 03000 267 979  
 SMS text message 0778 602 7280



### Darlington

 [www.darlington.gov.uk/Health/health.htm](http://www.darlington.gov.uk/Health/health.htm)  
 [enquiries@darlington.gov.uk](mailto:enquiries@darlington.gov.uk)  
 01325 346200 - Minicom: 01325 468504



### Stockton

 [www.stockton.gov.uk/adult-services/adult-social-care-requesting-care-and-support/](http://www.stockton.gov.uk/adult-services/adult-social-care-requesting-care-and-support/)  
 [firstcontact@stockton.gov.uk](mailto:firstcontact@stockton.gov.uk)  
 01642 527764 - Minicom: 01642 527769



### Hartlepool

 [www.hartlepool.gov.uk/info/20076/adults\\_and\\_older\\_people/405/getting\\_help\\_from\\_us](http://www.hartlepool.gov.uk/info/20076/adults_and_older_people/405/getting_help_from_us)  
 [fcsh@hartlepool.gov.uk](mailto:fcsh@hartlepool.gov.uk)  
 01429 284284 - Textphone: 01429 284130

### Middlesbrough

 [www.middlesbrough.gov.uk/index.aspx?articleid=1646](http://www.middlesbrough.gov.uk/index.aspx?articleid=1646)  
 [socialservices@middlesbrough.gov.uk](mailto:socialservices@middlesbrough.gov.uk)  
 01642 726004

### Redcar and Cleveland

 [www.redcar-cleveland.gov.uk](http://www.redcar-cleveland.gov.uk)  
 [contactus@redcar-cleveland.gov.uk](mailto:contactus@redcar-cleveland.gov.uk)  
 01642 771500

## North East Care Act Leads

The Care Act 2014 reformed the way in which adult social care and support is provided and financed. The social care reforms in the legislation came into force on 1 April 2015 and the financial reforms were implemented from 1 April 2016. Each local authority has a Care Act Lead who you can contact to find out more about how the new system is being implemented in your area.

### Northumberland

**Stephen Corlett**

✉ [Stephen.Corlett@northumbria-healthcare.nhs.uk](mailto:Stephen.Corlett@northumbria-healthcare.nhs.uk)

### Newcastle

**David Forster**

✉ [david.forster@newcastle.gov.uk](mailto:david.forster@newcastle.gov.uk)

### North Tyneside

**Sue Wood**

✉ [sue.wood@northtyneside.gov.uk](mailto:sue.wood@northtyneside.gov.uk)

### Gateshead

**Alex Cook**

✉ [alexcook@gateshead.gov.uk](mailto:alexcook@gateshead.gov.uk)

### South Tyneside

**Stephen Laverton**

✉ [Stephen.laverton@southtyneside.gov.uk](mailto:Stephen.laverton@southtyneside.gov.uk)

### Sunderland

**Richard Elliott**

✉ [Richard.Elliott@sunderland.gov.uk](mailto:Richard.Elliott@sunderland.gov.uk)

### Durham

**Paul Copeland**

✉ [paul.copeland@durham.gov.uk](mailto:paul.copeland@durham.gov.uk)

### Darlington

**Philippa Rayner**

✉ [philippa.rayner@durham.gov.uk](mailto:philippa.rayner@durham.gov.uk)

### Stockton

**Martin Waters**

✉ [martin.waters@stockton.gov.uk](mailto:martin.waters@stockton.gov.uk)

### Hartlepool

**Jeanette Willis**

✉ [jeanette.willis@hartlepool.gov.uk](mailto:jeanette.willis@hartlepool.gov.uk)

### Middlesbrough

**Iain Mackenzie**

✉ [iain\\_mackenzie@middlesbrough.gov.uk](mailto:iain_mackenzie@middlesbrough.gov.uk)

### Redcar and Cleveland

**Chris Moon**

✉ [chris.moon@redcar-cleveland.gov.uk](mailto:chris.moon@redcar-cleveland.gov.uk)

### Association of Directors of Adult Social Services Care Act Lead

**Liz Greer**

✉ [liz.greer@northeastcouncils.gov.uk](mailto:liz.greer@northeastcouncils.gov.uk)

### Government Statutory Guidance on implementing the Care Act

🖥 [www.gov.uk/government/publications/care-act-2014-statutory-guidance-for-implementation](http://www.gov.uk/government/publications/care-act-2014-statutory-guidance-for-implementation)

### Local Government Association Resources

🖥 [www.local.gov.uk/care-support-reform](http://www.local.gov.uk/care-support-reform)

### Social Care Institute for Excellence Resources

🖥 [www.scie.org.uk/care-act-2014/](http://www.scie.org.uk/care-act-2014/)

### Government Care Act Factsheets

🖥 [www.gov.uk/government/publications/care-act-2014-part-1-factsheets](http://www.gov.uk/government/publications/care-act-2014-part-1-factsheets)





# Health and Wellbeing Landscape

## North East Local Healthwatch Organisations





Healthwatch was launched in England on 1st April 2013 to give users of health and social care services a powerful voice - both locally and nationally. This information sheet provides contact details for the 12 Local Healthwatch organisations in the North East.

For information about **Healthwatch England** and to find out contact details for Healthwatch in other parts of the country visit [www.healthwatch.co.uk](http://www.healthwatch.co.uk) phone 03000 68 3000 or email [enquiries@healthwatch.co.uk](mailto:enquiries@healthwatch.co.uk)





### Healthwatch Northumberland

 [www.healthwatchnorthumberland.co.uk](http://www.healthwatchnorthumberland.co.uk)  
 03332 408 468  
 07413 385 275 (text)  
 [info@healthwatchnorthumberland.co.uk](mailto:info@healthwatchnorthumberland.co.uk)





### Healthwatch Sunderland

 [www.healthwatchesunderland.com](http://www.healthwatchesunderland.com)  
 0191 514 7145  
 Information and signposting: 0800 023 8840  
 [healthwatchesunderland@pcp.uk.net](mailto:healthwatchesunderland@pcp.uk.net)



### Healthwatch Newcastle

 [www.healthwatchnewcastle.org.uk](http://www.healthwatchnewcastle.org.uk)  
 0191 338 5720  
 07551 052751 (text)  
 Information and signposting: 0808 178 9282  
 [info@healthwatchnewcastle.org.uk](mailto:info@healthwatchnewcastle.org.uk)





### Healthwatch County Durham

 [www.healthwatchcountydurham.co.uk](http://www.healthwatchcountydurham.co.uk)  
 01325 375960  
 07756 654218 (text)  
 Information and signposting: 0808 801 0384  
 [info@healthwatchcountydurham.co.uk](mailto:info@healthwatchcountydurham.co.uk)





### Healthwatch North Tyneside

 [www.healthwatchnorthtyneside.co.uk](http://www.healthwatchnorthtyneside.co.uk)  
 0191 263 5321  
 [info@healthwatchnorthtyneside.co.uk](mailto:info@healthwatchnorthtyneside.co.uk)



### Healthwatch Darlington

 [www.healthwatchdarlington.co.uk](http://www.healthwatchdarlington.co.uk)  
 01325 380145  
 07525237723 (text)  
 Information and signposting: 0808 801 0383  
 [info@healthwatchdarlington.co.uk](mailto:info@healthwatchdarlington.co.uk)





### Healthwatch Gateshead

 [www.healthwatchgateshead.co.uk](http://www.healthwatchgateshead.co.uk)  
 0191 477 0033 or 0300 123 4008  
 Information and signposting: 0808 801 0382  
 [info@healthwatchgateshead.co.uk](mailto:info@healthwatchgateshead.co.uk)





### Healthwatch Hartlepool

 [www.healthwatchhartlepool.co.uk](http://www.healthwatchhartlepool.co.uk)  
 01429 262 641  
 [christopher@healthwatchhartlepool.co.uk](mailto:christopher@healthwatchhartlepool.co.uk)





### Healthwatch South Tyneside

 [www.healthwatchesouthtyneside.co.uk](http://www.healthwatchesouthtyneside.co.uk)  
 0191 489 7952  
 Information & signposting: 0808 801 0381  
 [info@healthwatchesouthtyneside.co.uk](mailto:info@healthwatchesouthtyneside.co.uk)





### Healthwatch Stockton-on-Tees

 [www.healthwatchstocktonontees.co.uk](http://www.healthwatchstocktonontees.co.uk)  
 01642 688312  
 Information and signposting: 0808 1729 559  
 [healthwatchstockton@pcp.uk.net](mailto:healthwatchstockton@pcp.uk.net)

## Healthwatch Middlesbrough

 [www.healthwatchmiddlesbrough.co.uk](http://www.healthwatchmiddlesbrough.co.uk)  
 01642 688312  
 Information and signposting: 0808 1729 559  
 [healthwatchmiddlesbrough@pcp.uk.net](mailto:healthwatchmiddlesbrough@pcp.uk.net)

## Healthwatch Redcar & Cleveland

 [www.healthwatchredcarandcleveland.co.uk](http://www.healthwatchredcarandcleveland.co.uk)  
 01642 688312  
 Information and signposting: 0808 1729 559  
 [healthwatchredcarcleveland@pcp.uk.net](mailto:healthwatchredcarcleveland@pcp.uk.net)

## North East Joint Strategic Needs Assessments

The Joint Strategic Needs Assessment (JSNA) is a process that involves local authorities, Public Health, NHS organisations, service users and the community and voluntary sector, working together to identify the health and wellbeing needs of their local area. It is a way of collecting, analysing and using evidence to shape how services should be commissioned and delivered. JSNA information is available on a website but sometimes a summary document is produced.

### How does it work?

- Partners from local authorities, public health, the community and voluntary sector, service users and the NHS research and agree a comprehensive picture of health and wellbeing needs for their area.
- Partners undertake research and analysis - what's working, what's not, what could work better, what are the unmet needs and gaps in local provision?
- Partners produce a Strategic Needs Assessment which is then used to agree the health and wellbeing priorities for their local area. You can find the top 3 local priorities on the VONNE website.
- Future commissioning and decision-making are influenced by and respond to the needs assessment and the strategic priorities.
- A summary on the strategic picture for health and wellbeing is made available to the public, voluntary and community sector, providers and so on.

Building on the needs and assets identified through the JSNA Health and Wellbeing Boards are required to produce a strategy that will drive all commissioning of services in their area. Decisions about what services to commission should always be justifiable by what is in the JSNA.

You can view your local JSNA here. The JSNA should be reviewed and refreshed regularly and there should be an opportunity for voluntary and community groups to provide relevant information and evidence and about the needs and wants in their area or field of work. This will often be done through the local Health and Wellbeing Board but we have given a JSNA contact where one is available.

You can read a recent Briefing 'Comparing apples with oranges' which looks in more detail at how the voluntary and community sector can contribute to their JSNA. You can find this and more resources on influencing your JSNA on the Regional Voices website at [www.regionalvoices.org](http://www.regionalvoices.org)

# Health and Wellbeing Landscape

## Northumberland JSNA

You can download the JSNA and view other information on the website here:

 [www.northumberland.gov.uk](http://www.northumberland.gov.uk)

**Contact:** Pamela Forster

 [pamela.Forster@northumberland.gcsx.gov.uk](mailto:pamela.Forster@northumberland.gcsx.gov.uk)

## Newcastle JSNA – known as Newcastle Future Needs Assessment (NFNA)

You can view Know Newcastle here:

 [www.knownewcastle.org.uk](http://www.knownewcastle.org.uk)

**Contact:** Helen Wilding

 [helen.wilding@newcastle.gov.uk](mailto:helen.wilding@newcastle.gov.uk)

## North Tyneside JSNA

You can download the 2016 JSNA and look at background documents etc. here:

 [www.northtyneside.gov.uk](http://www.northtyneside.gov.uk)

## Gateshead JSNA

You can download the most recent JSNA here:

 [www.gateshead.gov.uk/Health-and-Social-Care/JSNA/home.aspx](http://www.gateshead.gov.uk/Health-and-Social-Care/JSNA/home.aspx)

**Contact:** Sonia Stewart

 0191 433 3045

 [soniastewart@gateshead.gov.uk](mailto:soniastewart@gateshead.gov.uk)

## South Tyneside JSNA

You can view the JSNA documents and reports here:

 [www.southtyneside.gov.uk/article/13236/Joint-Strategic-Needs-Assessment-documents](http://www.southtyneside.gov.uk/article/13236/Joint-Strategic-Needs-Assessment-documents)

**Contact:** Health and Social Inclusion JSNA

 0191 424 7647

 [jsna@southtyneside.gov.uk](mailto:jsna@southtyneside.gov.uk)

## Sunderland JSNA

You can view the JSNA documents and reports here:

 [www.sunderlandpartnership.org.uk/healthy.html](http://www.sunderlandpartnership.org.uk/healthy.html)

**Contact:** Yvonne Ewington, Partnership Engagement Officer

 0191 561 1163

 [sunderland.partnership@sunderland.gov.uk](mailto:sunderland.partnership@sunderland.gov.uk)

## Durham JSNA

You can view the JSNA documents and reports here:

 [www.durham.gov.uk/jsna](http://www.durham.gov.uk/jsna)

**Contact:** Joint Strategic Needs Assessment Planning and Policy Team

 [hwbadmin@durham.gov.uk](mailto:hwbadmin@durham.gov.uk)

## Darlington JSNA

You can download the JSNA and other information from:

 [www.darlington.gov.uk/your-council/council-information/documents/strategic-needs-assessment/](http://www.darlington.gov.uk/your-council/council-information/documents/strategic-needs-assessment/)

**Contact:** Janet Walke

 01325 406085

 [pamela.Forster@northumberland.gcsx.gov.uk](mailto:pamela.Forster@northumberland.gcsx.gov.uk)

## Stockton JSNA

There is a joint website for the four Tees JSNAs, the Stockton section is:

 [www.teesjsna.org.uk/stockton/](http://www.teesjsna.org.uk/stockton/)

**Contact:** Leon Green, Public Health Intelligence Specialist

 01642 745205

 [leon.green@tees.nhs.uk](mailto:leon.green@tees.nhs.uk)

## Hartlepool JSNA

There is a joint website for the four Tees JSNAs, the Hartlepool section is:

 [www.teesjsna.org.uk/hartlepool/](http://www.teesjsna.org.uk/hartlepool/)

**Contact:** Leon Green, Public Health Intelligence Specialist

 01642 745205

 [leon.green@tees.nhs.uk](mailto:leon.green@tees.nhs.uk)

## Middlesbrough JSNA

There is a joint website for the four Tees JSNAs, the Middlesbrough section is:

 [www.teesjsna.org.uk/middlesbrough/](http://www.teesjsna.org.uk/middlesbrough/)

**Contact:** Leon Green, Public Health Intelligence Specialist

 01642 745205

 [leon.green@tees.nhs.uk](mailto:leon.green@tees.nhs.uk)

## Redcar & Cleveland JSNA

There is a joint website for the four Tees JSNAs, the Redcar & Cleveland section is:

 [www.teesjsna.org.uk/redcar-and-cleveland/](http://www.teesjsna.org.uk/redcar-and-cleveland/)

**Contact:** Leon Green, Public Health Intelligence Specialist

 01642 745205

 [leon.green@tees.nhs.uk](mailto:leon.green@tees.nhs.uk)

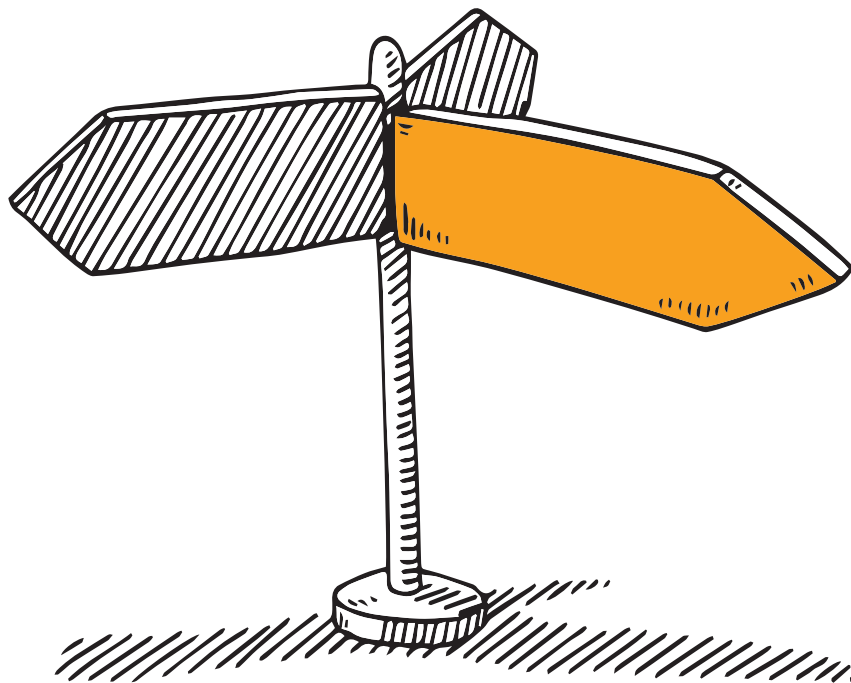



## Care Quality Commission

The Care Quality Commission (CQC) is England's independent health and adult social care regulator. It monitors, inspects and regulates services to make sure they meet standards of quality and safety and publish these findings, including performance ratings to help people choose care.

The CQC set out what good and outstanding care looks like and make sure that services meet these fundamental standards of care. Where poor care is found, the CQC have the power to take action.

The CQC look to the VCSE sector, as well as individuals, to provide information on the experience of care their service users' experience. You can contact the CQC to share information on care in the following ways:

 [www.cqc.org.uk/share-your-experience-finder](http://www.cqc.org.uk/share-your-experience-finder)

 [enquiries@cqc.org.uk](mailto:enquiries@cqc.org.uk)

 03000 61 61 61

# Health and Wellbeing Landscape

## The Northern England Clinical Senate

The Northern England Clinical Senate is one of 12 established across England to be a source of independent, strategic advice and guidance on clinical matters, looking at the whole 'birth to death' spectrum of care. The Senate works with commissioners and other stakeholders to assist them to make the best decisions about healthcare for the populations they represent, based on local priorities. The Senate will, for example, be involved when services are being re-configured, ensuring that service changes are based on sound clinical evidence.

- The Senate Council forms the core steering group and is supported by the Senate Assembly. Clinical Senate Council membership comprises; multi-professional clinicians, NHS commissioners and providers, patient and public groups, public health and social care specialists, educationalists and third sector representatives.
- Appointment of members is carried out through a fair and transparent process and overseen by Area Team Medical Director with professional input as appropriate. The VONNE CEO is a member of the Senate Council.

The wider Clinical Senate Assembly is brought together virtually depending on the topic. The Assembly is a diverse multi-professional forum providing the Council with ready access to experts from a broad range of health and care professions.

The Northern England Clinical Senate covers North Cumbria, Northumberland, Tyne & Wear, Durham, Darlington, Tees, and the Hambleton & Richmond Districts of North Yorkshire.

You can contact the Northern Clinical Senate through the Senate Manager, Michelle Wren -  
✉ email: [michelle.wren@nhs.net](mailto:michelle.wren@nhs.net)

The Northern England Clinical Senate Website is

🖥 [www.nesenate.nhs.uk](http://www.nesenate.nhs.uk)

The Senate is based at:

NHS England  
Ground Floor, Waterfront 4  
Newburn Riverside  
Newcastle upon Tyne  
NE15 8NY

## Northern England Strategic Clinical Networks (NESC�)

Strategic Clinical Networks were set up in 2013 to build on the success of previous networks in improving the way care is provided. The Northern England Networks work across the boundaries of commissioner, provider and voluntary organisations to improve services for patients, carers and the public. The Networks aim to:

- Reduce unwarranted variation in health and wellbeing services
- Encourage innovation in how services are provided now and in the future
- Provide clinical advice and leadership to support decision making and strategic planning.

Whilst continuing to support work already established, four new strategic clinical networks have been established covering the following areas:

- Cardiovascular (including cardiac, stroke, renal and diabetes)
- Maternity, Children and Young People
- Mental Health, Dementia and Neurological Conditions
- Cancer



## Northern Clinical Senate Members

	NAME	ORGANISATION	SPECIALITY
<b>Senate Team</b>	Andrew Cant	Northern Clinical Senate/The Newcastle upon Tyne Hospitals NHS Foundation Trust	Senate Chair
<b>NHS England: Cumbria and the North East</b>	Jonathan Slade	NHS England, Cumbria and the North East DCO Team	Medical Director
	Robin Mitchell	Clinical Networks and Senate	Clinical Director
	Bev Reilly	NHS England: Cumbria and the North East	Director of Nursing and Quality
<b>Nominated members</b>	Alex Glover	Health Education North East	Managing Director
	Jane Hartley	VONNE	Health and wellbeing Policy Officer
	Roberta Marshall	Public Health England	Centre Director
	Jacqui Old	Community Services Directorate	Head of Adult Social Care
	Seamus O'Neill	Academic Health Science Network	CEO
	Peter Weaving	North Cumbria University Hospitals Trust	GP Clinical Director
<b>Recruited members</b>	Catherine Baldrige		Pharmacist
	Richard Bellamy		Consultant Infectious Disease/ Chief of Academic Division
	Alistair Blair		GP/Chief Clinical Officer
	Derek Cruikshank		Consultant Gynae/Onc
	Maurya Cushlaw		Accountable Officer / Chief Officer
	David Evans		Medical Director (Trauma)
	Elizabeth Harris		Head of Nursing
	Mark Hudson		Medical Lead for Liver
	Lesley Kay		Consultant Rheumatologist Lead in Undergraduate research
	Hilary Lloyd		Deputy Director of Nursing, Midwifery and Quality
	Jeremy Murphy		Consultant Physician
	Jon Scott (Vice chair)		Physician - Elderly Care supports stroke across SOTW
Jonathan Smith		Principal GP	
<b>Co-opted members</b>	Mike Jones	County Durham and Darlington NHS Foundation Trust	Consultant on Acute Medicine
	Stephen Strugiss	The Newcastle upon Tyne Hospitals NHS Foundation Trust	Consultant Obstetrician
	Gareth Hosie	The Newcastle upon Tyne Hospitals Foundation Trust	Consultant Paediatric Surgeon
<b>Senate Support</b>	Roy McLachlan	Clinical Networks and Senate	Associate Director
	Michelle Wren	Clinical Networks and Senate	Network and Senate Delivery Facilitator
	Ben Clark	Clinical Networks and Senate	Senate Manager

You can contact the Voluntary & Community Sector representative through [jane.hartley@vonne.org.uk](mailto:jane.hartley@vonne.org.uk) and other members via [england.northernclinicalsenate@nhs.net](mailto:england.northernclinicalsenate@nhs.net)

# Health and Wellbeing Landscape

In addition the NESCN has three work streams that follow the patient's pathway:

- Prevention, Awareness and Early Diagnosis
- Treatment and Patient Experience
- Long Term Conditions, Living with and End of Life Care

Northern England Strategic Clinical Networks work closely with, and support the work of, the Senate often providing clinical 'evidence' and guidance. The Networks cover North Cumbria,

Northumberland, Tyne & Wear, Durham, Darlington, Tees, and the Hambleton & Richmond Districts of North Yorkshire.

Full current contact details for all the Networks are available on the Contacts page of their website:

 [www.nescn.nhs.uk](http://www.nescn.nhs.uk)

## The Academic Health Science Network for the North East and North Cumbria (AHSN NENC)

Following the publication of the Innovation, Health and Wealth Report published in December 2011, the Department of Health created 15 regional Academic Health Science Networks to identify, adopt and disseminate innovative healthcare in the NHS.

The vision for the Network in the North East and North Cumbria is to create an integrated organisation in which Members are collectively committed to improving both the health and wealth of the region through innovation, research and the dissemination of knowledge, as well as the adoption of new and improved products and services.

By working in partnership with Core Member Organisations, including NHS Foundation Trusts, Clinical Commissioning Groups, Universities and a wide range of other stakeholders including companies, charities and Local Authorities, the Network aims to ensure that areas of best

practice and innovation are identified and disseminated, at pace and scale, regionally and nationally. Details of some of their work is available on the Networks website:

 [www.ahsn-nenc.org.uk](http://www.ahsn-nenc.org.uk)

You can contact the AHSN NENC via the website, by phone on 0191 208 1326, email on [enquiries@ahsn-nenc.org.uk](mailto:enquiries@ahsn-nenc.org.uk) or by post at:

Seamus O'Neill  
Room 2.13  
Biomedical Research Building  
The Campus for Ageing and Vitality  
Nuns' Moor Road  
Newcastle upon Tyne  
NE4 5PL

## Sustainability and Transformation Plan (STP)

Sustainability and Transformation Plans (STPs) are seen as the key mechanism for implementing the NHS Five Year Forward View (FYFV) and its vision of better health and wellbeing, improved quality of care, and a sustainable and efficient NHS.

STPs are a key element on the NHS Shared Planning Guidance and the local implementation of the Five Year Forward View.

They are supported by six of the national health and care bodies:

NHS England, NHS Improvement, the Care Quality Commission (CQC), Health Education England (HEE), Public Health England (PHE) and the National Institute for Health and Care Excellence (NICE).

## Contacts in the North- Footprint and Footprint Lead

### Northumberland Tyne and Wear

Mark Adams (Chief Officer, Newcastle and Gateshead CCG)

✉ [ngccg.enquiries@nhs.net](mailto:ngccg.enquiries@nhs.net)

☎ 0191 217 2996

### Durham (Includes Durham Dales, Easington & Sedgfield CCG area) Darlington and Tees, Hambleton, Richmondshire and Whitby.

Alan Foster (Chief Executive, North Tees and Hartlepool NHS Foundation Trust)

✉ [alan.foster@nth.nhs.uk](mailto:alan.foster@nth.nhs.uk)



# Health and Wellbeing Landscape

## North East Health Scrutiny Bodies

### Northumberland Care and Wellbeing Overview and Scrutiny Committee

 [www.northumberland.gov.uk](http://www.northumberland.gov.uk)

### Newcastle Health Scrutiny Committee

 [www.newcastle.gov.uk](http://www.newcastle.gov.uk)

### North Tyneside Adult Social Care, Health and Wellbeing Sub-committee

 [www.northtyneside.gov.uk](http://www.northtyneside.gov.uk)

### Gateshead Care, Health and Wellbeing Overview and Scrutiny Committee

 [www.gateshead.gov.uk](http://www.gateshead.gov.uk)

### South Tyneside Overview and Scrutiny Coordinating and Call-in Committee

 [www.southtyneside.info](http://www.southtyneside.info)

### Sunderland - Public Health, Wellness and Culture Scrutiny Panel

### Sunderland - Health, Housing and Adult Services Scrutiny Panel

Sunderland has two Scrutiny Panels covering Health and wellbeing.

 [www.sunderland.gov.uk](http://www.sunderland.gov.uk)

### Durham Adults, Wellbeing and Health Scrutiny Committee

 [www.durham.gov.uk](http://www.durham.gov.uk)

### Darlington Health and Partnerships Scrutiny Committee

 [www.darlington.gov.uk](http://www.darlington.gov.uk)

### Stockton Adult Services and Health Select Committee

 [www.stockton.gov.uk](http://www.stockton.gov.uk)

### Hartlepool Audit and Governance Committee

 [www.hartlepool.gov.uk](http://www.hartlepool.gov.uk)

### Middlesbrough Health Scrutiny Panel

 [www.middlesbrough.gov.uk](http://www.middlesbrough.gov.uk)

### Redcar and Cleveland People Services Scrutiny & Improvement Committee

 [www.redcar-cleveland.gov.uk](http://www.redcar-cleveland.gov.uk)

### South Tees Health Scrutiny Joint Committee for Middlesbrough and Redcar and Cleveland

This is a Joint Scrutiny Committee of the two authorities which meets regularly.

 [www.middlesbrough.gov.uk](http://www.middlesbrough.gov.uk)

### Tees Valley Health Scrutiny Joint Committee

There is a standing Tees Valley Health Scrutiny Joint Committee which meets to discuss issues across the Tees Valley councils of Darlington, Hartlepool, Middlesbrough, Redcar and Cleveland and Stockton on Tees.

 [www.hartlepool.gov.uk](http://www.hartlepool.gov.uk)

# A guide to the Criminal Justice System in the North East

This section has been developed to provide details about the different elements of the Criminal Justice System and provide the sector with North East contact details.

## Police

In the North East there are 3 police force areas; Northumbria, Durham and Cleveland. They are held to account by publicly elected Police and Crime Commissioners.

### Police and Crime Commissioners

Northumbria	<b>Vera Baird QC</b>	✉ enquiries@northumbria-pcc.gov.uk
Durham	<b>Ron Hogg</b>	✉ enquiries@durham-pcc.gov.uk
Cleveland	<b>Barry Coppinger</b>	✉ pcc@cleveland.pnn.police.uk

The Police and Crime Commissioners work to ensure the needs of the local communities they represent are met effectively, through creating and influencing decisions which will have an impact on your local area. By building relationships with communities and inspiring confidence in the police force, the commissioners aim to be the public voice on policing matters.

## Northumbria Police Force Area

Northumbria Police cover more than 2,000 square miles, from the Scottish border to County Durham; from the Pennines to the North East coast. It is made up of the boroughs of North and South Tyneside, Sunderland, Newcastle, Gateshead and the County of Northumberland.

It has a population of 1.4 million people. Crime has continuously fallen over the last 15 years. 2011/12 end of year figures show the total number of crimes as 75,504 compared with 1992 where there were 203,972 recorded crimes.

### Police and Crime Commissioner: Vera Baird QC

Vera Baird has produced a five year police and crime plan and the five objectives are:

- Putting Victims First
- Dealing with Anti-social Behaviour
- Domestic and Sexual Abuse
- Reducing Crime
- Community Confidence

More information about Northumbria Police Force and local neighbourhood policing teams can be found at [www.northumbria.police.uk](http://www.northumbria.police.uk)

**Chief Constable** – Steve Ashman

More information about Northumbria Police Force and local neighbourhood policing teams can be found at [www.northumbria.police.uk/about\\_us/](http://www.northumbria.police.uk/about_us/)

## Durham Police Force Area

Durham force area has a total population of more than 600,000 people covering a total of 860 square miles. This includes the historic city of Durham, the major town of Darlington, numerous smaller towns and villages and the largely rural areas of Teesdale and Weardale.

The force continues to perform well and is currently seeing reduced levels of crime and anti-social behaviour when compared with 2011/12. As a result, recorded crime is at its lowest level since 1983 with County Durham and Darlington having some of the lowest crime rates nationally.

**Police and Crime Commissioner:** Ron Hogg

A Police and Crime Plan has been produced which sets out Ron Hogg's vision "To achieve excellence in local policing and the highest levels of public confidence by working alongside communities and partners to address what matters locally." The plan sets out four key objectives:

- Inspire Confidence
- Support Victims
- Keeping Communities Safe
- Deliver an efficient policing service

More information about the work of the PCC and his Police and Crime Plan can be found at [www.durham-pcc.gov.uk](http://www.durham-pcc.gov.uk)

**Chief Constable** - Michael Barton

More information about Durham Police Force and local neighbourhood policing teams can be found at [www.durham.police.uk/Pages/default.aspx](http://www.durham.police.uk/Pages/default.aspx)

## Cleveland Police Force Area

The Cleveland Police area covers approximately 230 square miles and has a population of over 554,000. Cleveland Police area is divided into four policing basic command units, known locally as districts, which are coterminous with the four unitary authorities of Hartlepool, Redcar and Cleveland, Middlesbrough and Stockton-on-Tees. The force is responsible for policing a predominantly urban, densely populated area, closely resembling metropolitan authorities in socio-economic characteristics and policing needs.

**Police and Crime Commissioner:** Barry Coppinger

Barry has produced a 4 year Police and Crime Plan which sets out a number of key objectives:

- Retaining and developing Neighbourhood Policing
- A better deal for victims and witnesses
- Diverting people from crime
- Partnership working to maximise resources
- Better industrial and community relations

More information about the work of the PCC and his Police and Crime Plan can be found at [www.cleveland.pcc.police.uk](http://www.cleveland.pcc.police.uk)

**Chief Constable** - Iain Spittal

More information about Cleveland Police Force and local neighbourhood policing teams can be found at [www.cleveland.police.uk](http://www.cleveland.police.uk)

## Crown Prosecution Service North East

The Crown Prosecution Service (CPS) was set up in 1986 to prosecute criminal cases investigated by the police in England and Wales.

The CPS is responsible for deciding whether there is sufficient evidence to charge and prosecute an alleged offender. There are also specialists whose job it is to pursue the proceeds of crime, ensuring that money made through their illegal activities is clawed back.

Within Witness Care Units, CPS staff work extremely closely with the police and Victim Support to provide information, support, and advice to victims and witnesses. The work they do is often the key to achieving a successful conviction.

In undertaking this role, CPS North East continues to:

- Advise police forces in Northumbria, Durham and Cleveland on cases for possible prosecution
- Review cases submitted by the police for prosecution
- Determine the charge in all serious cases
- Prepare cases for court
- Present those cases at court

**Chief Crown Prosecutor** – Gerry Wareham

Telephone 0191 260 4200 or for more information about The Crown Prosecution Service can be found at [www.cps.gov.uk/northeast/who\\_we\\_are/](http://www.cps.gov.uk/northeast/who_we_are/)

## The Courts

The courts are divided into magistrates and crown courts. All cases are initially heard at magistrates courts. If offences are less serious they can only be dealt with at this level. Some cases can be dealt with either at the Magistrates or Crown Court. More serious offences must be referred by magistrates court to Crown Court.

Magistrates are volunteers that have been specially trained and have the support and advice of legally qualified court clerks.

Find your nearest court or tribunal in the North East: <https://courtribunalfinder.service.gov.uk/>

## Probation Service

From 1st June 2014 Probation Trusts split into publicly owned Community Rehabilitation Companies (CRC's) and a National Probation Service.

CRC staff work to protect the public, reduce reoffending, support victims and rehabilitate offenders. The probation service supervise adult offenders serving community orders and released from prison on licence and work with other agencies to provide offenders with help and support with accommodation, employment and education, drug treatment and debt advice.

Probation Trusts also lead on Multi-Agency Public Protection Arrangements (MAPPA) which is a system for bringing together agencies to manage sexual and violent offenders. Under the new reforms the new National Probation Service will have responsibility for MAPPA.

In the North East, there are two CRC's.

### Northumbria Community Rehabilitation Company

Head Office, 1st Floor, The Lightbox, Quorum Business Park, Benton Lane, Newcastle upon Tyne, NE12 8EU

**Head of Business** – Louise Mann

✉ [louise.mann@sodexojustice.scc.gsi.gov.uk](mailto:louise.mann@sodexojustice.scc.gsi.gov.uk)

☎ 0345 608 0204

### Durham Tees Valley Community Rehabilitation Company

Wear House, Unit 14, Mandale Park, Belmont Industrial Estate, Durham, DH1 1TH

**Gate Manager** – Helen Raine

✉ [Helen.Raine@dtvcrcsecure.co.uk](mailto:Helen.Raine@dtvcrcsecure.co.uk)

☎ 0808 168 48 48

The **North East Division of National Probation Service (NPS)** stretches from the Scottish border down to Lincolnshire. It works with 5 CRC's across the division, including Northumbria, Durham Tees Valley, West Yorkshire, South Yorkshire, and Humberside, Lincolnshire & North Yorkshire.

The deputy director for the NPS North East division is Lynda Marginson.

✉ [NEdivisionaloffice.generalenquiries@probation.gsi.gov.uk](mailto:NEdivisionaloffice.generalenquiries@probation.gsi.gov.uk)



## HMP Prison Service

There are 7 prisons in the North East of England. They are categorised according to the level of security each one provides.

Category A prisons hold the most dangerous prisoners. The rest of the prison estate comprises Category B prisons, Category C (training) prisons, Category D (open or resettlement) prisons.

### 1 HMYOI Deerbolt

Bowes Road, Barnard Castle, County Durham, DL12 9BG

**Governor:** Gavin O'Malley

 01833 633200

Deerbolt is a Category C young offenders establishment that caters for approximately 500 male young offenders between the ages of 18 – 21, generally serving sentences up to 4 years in length.

### 2 HMP Durham

Old Elvet, Durham, DH1 3HU

**Governor:** Tim Allen

 0191 332 3400

HMP Durham is a Category B local prison which accommodates 1,017 young offenders age 18 – 21, adult males over 21; sentenced, convicted or remanded from the Tyneside, Durham and Cumbria courts.

### 3 HMP Frankland

Brasside, Durham, DH1 5YD

**Governor:** Norman Griffin

 0191 376 5000

HMP Frankland accommodate Category A and B adult males serving 4 years and over, in-determined or life sentences plus high and standard risk category A remands.

### 4 HMP Holme House

Stockton on Tees, TS18 2QU

**Executive Governor:** Jenny Mooney

**Governor:** Chris Dyer

 01642 744000

Holme House is a large Category B local prison for male adult prisoners, remand and convicted: It also holds a small number of young men on remand (18-21). Along with Kirkevington Grange, Holme House is now a reform prison with strategic direction provided by an Executive Governor.

### 5 HMP Kirklevington Grange

Yarm, Cleveland, TS15 9PA

**Executive Governor:** Angie Pertit

**Governor:** Angie Petit

 01642 792600

HMP Kirklevington is a Category C and D semi open prison. It was built as a resettlement prison for 283 adult male offenders. Along with Holme House, Kirkevington is now a reform prison with strategic direction provided by an Executive Governor.

### 6 HMP and YOI Low Newton

Brasside, Durham, DH1 5YA

**Governor:** Alan Richer

 0191 3764000

Low Newton is a closed, female prison and young offender institution accommodating 336 women. It holds a small number of life sentenced prisoners. Low Newton serves the courts in the catchment area from the Scottish Borders to North Yorkshire across to North Cumbria.

### 7 HMP Northumberland

Morpeth, Northumberland, NE65 9XG

**Director:** Tony Simpson

 01670 762300

HMP Northumberland is a Male Adult Category C prison and has the capacity to accommodate 1348 prisoners. From the 1 December 2013 HMP Northumberland formally transferred to the management of Sodexo Justice Services.

# A guide to the Criminal Justice System in the North East

## Community Safety Partnerships

### Northumberland Safer Partnership

Chair: Liz Simpson

✉ Safernorthumberland@northumberland.gov.uk

### Safer Newcastle

Chair: Cllr Stephen Powers

✉ safenewcastle@newcastle.gov.uk

### South Tyneside Community Safety

Chair: Cllr Moira Smith

✉ community.safety@southtyneside.gov.uk

### Safe Durham Partnership

Chair: Rachel Shimmin

✉ safedurhampartnership@durham.gov.uk

### Safer Hartlepool

Chair: Cllr Christopher Akers-Belcher

✉ community.safety@hartlepool.gov.uk

### Middlesbrough Community Safety

Manager: Rachel Beard

✉ antisocialbehaviourunit@middlesbrough.gov.uk

### Safer North Tyneside

Chair: Cllr Carole Burdis

✉ carole.burdis@northtyneside.gov.uk

### Safer Gateshead

Chair: 0191 433 3000

✉ communitysafety@gateshead.gov.uk

### Safe Sunderland Partnership

Chair: Cllr Thomas Foster

✉ community.safety@sunderland.gov.uk

### Darlington Community Safety Partnership

Chair: Chief Superintendent Graham Hall

✉ djsnu@durham.pnn.police.uk

### Safer Stockton Partnership

Chair: Steve Nelson

✉ communitysafetyteam@stockton.gov.uk

### Redcar and Cleveland Community Safety Partnership

Manager: Jay Hosie

✉ Jay.Hosie@redcar-cleveland.gov.uk



Registered Office:  
4th Floor, MEA House  
Ellison Place  
Newcastle  
Tyne and Wear  
NE1 8XS

Tel: 0191 233 2000  
vonne@vonne.org.uk  
www.vonne.org.uk

 @VONNEnews @VONNEjobs @FundingINE

Registered Charity: 1084083 Registered Company Limited by Guarantee: 4061592